

Automatic fuel conditioning system for large capacity fuel storage installations

The SAFA automatic fuel conditioning system for particle filtration, water removal, fuel homogenization and oxygenation through its programmed recirculation protocol, prevents the proliferation of bacteria, molds and yeasts that are liable to damage the installation.

- The SAFA is a bespoke system, able to prevent fuel degradation in up to 6 storage tanks, from 1.000 liters till 100.000 each.
- Configured and equipped with all the necessary elements to control filtering protocol of existing tanks, it is designed in a scalable technique to allow future extensions of the fuel storage park.
- All manoeuvres and alarms are locally displayed at the LCD touchscreen, and remotely by mod-bus.



TECHNICAL CHARACTERISTICS	
Dimensions (Hydraulic part)	1000x700x1300 mm
Dimensions (Control Cabinet)	600x600x200
Power supply	III / 400 V
Consumption	1,2A
Standard flow rate	1500 L/h
Motor	3/4 CV
Suction / Drive	2" - 2"
Recommended for storage tanks above 1,000 L.	

- Circulates and prevents fuel degradation inside storage tanks.
- Fuel is passed through a fuel conditioner to prevent microbial growth.
- The fuel is automatically distributed for a adjustable number of periods programmed by the operator. We recommend to ensure that the contents of the tank are recirculated at a rate of 1.5 times tank's capacity every 28 days.
- If water is detected in the decanting filter in the unit, it triggers an alarm and pump starts an automatic water drain process.
- The system is powered by 400 Vac triphase power supply (a version on 230 V are available under request) and comprises a double stage particle and water decanting filter, fuel conditioner, flow detector, flow failure display, timer.

Filtering System Basic Diagram

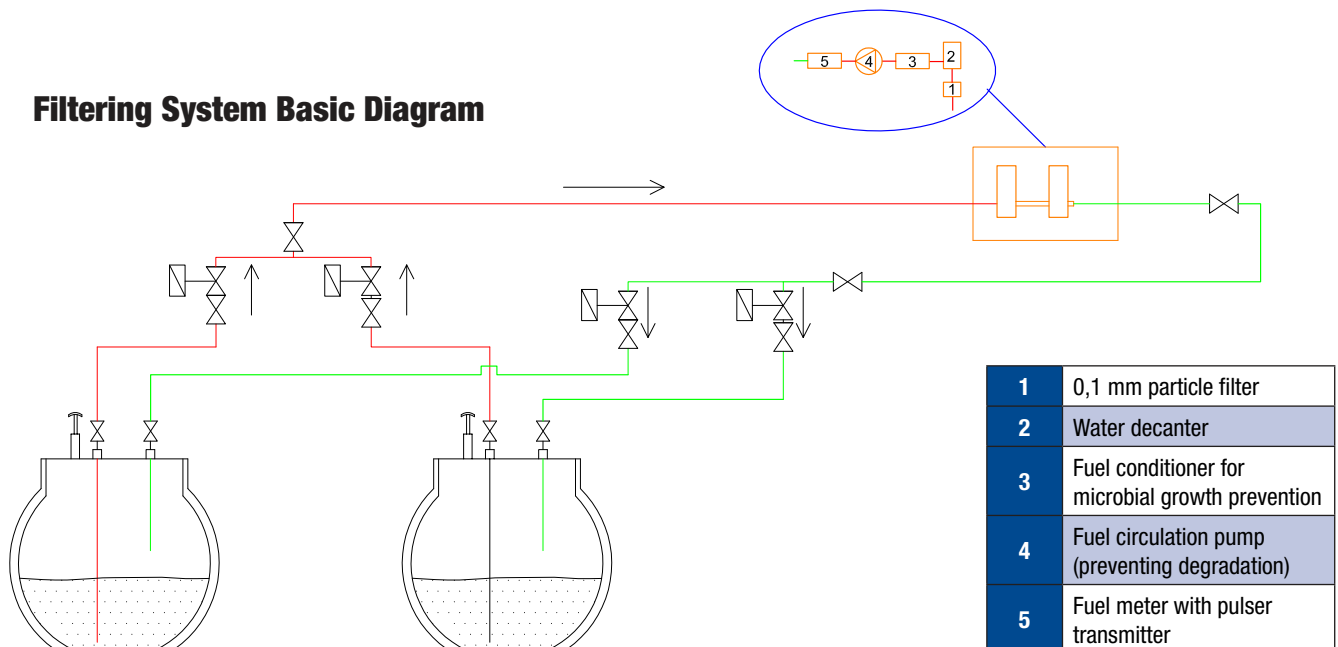

System Description

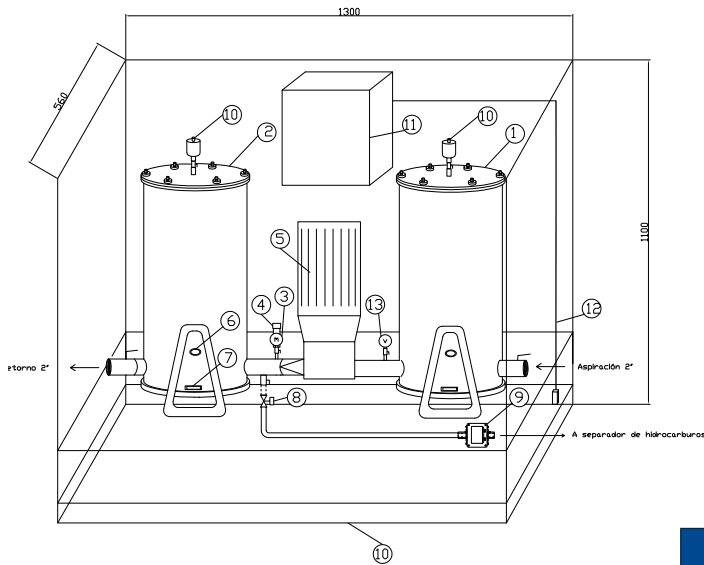

1	1st Filter 50 microns	9	Water draining pump
2	2nd Filter 15 microns	10	Automatic air vent
3	Pressure gauge glycerine	11	Junction box
4	Analog Pressure switch 0-10 bar	12	Leak detector
5	Motorpump 1.500 l / h	13	Vacuum gauge
6	Water viewer (electrode type)	14	Control cabinet (600x600x200)
7	Dirty filter warning	15	Flow meter with pulser
8	Water draining solenoid valve	16	Fuel Conditioner

Detailed Scope of Contents:

Automatic Fuel Polisher and Drain System

- 1.500 lts/h motorpump III/400 3/4 CV/1,2A.
- Pressure sensor- linear.
- Vacuum gauge meter.
- Manometer glycerine 0-10 bar.
 - Sampling cap.
 - 2 Aluminium Microfilters FG-300 / 15-25
 - 1 50 µm particle filter (micron).
 - 1 second stage filter 15 µm (micron) water absorbent filtering paper.
- Water presence gauge.
- Differential pressure gauge, as clogged filter indicator
- Sensors for water detection to start automatic water drainage.
- Solenoid-valve N/C 3/8 "drain line.
- Pump solenoid type 12 Lts / h drain line.
- Manual drain ball valves.
- Leak collecting tray, in metal, epoxy painted.
- Infrared leak detector.
- Metal cabinet in metal, epoxy painted.
- Sizes may change according special bespoke requirements.
- Maximum work pressure: 6 bar.
- Maximum system pressure: 10 bar.

LCD Touchscreen Display and Control Cabinet

- Software programmed PLC controller with touch screen.
 - Analog and digital inputs and outputs (any required)
 - Mod-Bus communication.
- Motor starters and thermal protection for motor pumps.
- 24Vdc power supply transformer.
- Connection terminals.
- System ready mounted with all bespoke necessary equipment, factory tested and ready to set up.
- Control cabinet IP66, in metal, epoxy painted with PLC controller display mounted at front panel.

Automatic Protocol Description:

FILTER PROTOCOL

The status of the SAFA filter system is displayed on the PLC screen. In this screen you can select and modify the working modes for SAFA, see alarms and cancel the system.

AUTOMATIC FILTERING MODE

When the automatic filtering mode is selected, the days from Monday to Sunday and the filtration start time can be selected. The total filtering time per tank, can be adjusted up to 59 minutes per tank.

At the scheduled time of each day selected, the suction and return solenoid valves of the line of the first tank will be opened. Once the filtration time has elapsed, continue with the next tank, opening and closing the corresponding solenoid valves. So with all the tanks the filtration is concluded.

The protocol can be manually stopped at any time by pressing "Off" closing the solenoids and the system shutdown. Program is suspended.



MANUAL FILTERING MODE

When the manual filtering mode is selected, the tank to be filtered can be manually selected through the PLC screen.

By pressing "SAFA Start" the filtering system opens return and return electrovalves that give access to the preferred tank, and it will remain in operation for unlimited time.

The protocol can be stopped manually at any time by pressing "SAFA Start" again, closing the line solenoid valves.

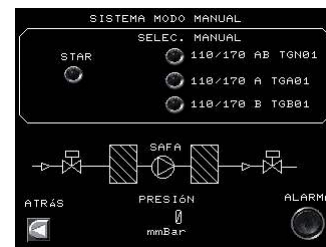

AUTOMATIC DRAIN PROTOCOL

By means of the water detectors installed at each of the filters, the automatic drainage protocol will be activated towards the water decanter.

Any filtering protocol is locked. The 3/8"NC solenoid valve of the drain is opened and the solenoid pump is activated for 30"

The filtering system keeps blocked for the next 10 minutes.

Each of the filters has a water presence gauge on the front of the filter housing. In the filters there is a differential pressure drop gauge, as clogged filter indicator.



DRAINING FILTERS AND CLEANING OR REPLACING FILTER CARTRIDGES

In order to empty the filters for cleaning or replacing the filter cartridges, the system must first be set to "Off", the main suction and pressure valves closed and the plug from the three-way drain valves located at the back of filters removed. A container should be placed to avoid that the drop of fuel to the collecting tray causes leak detection alarms, and open the drain valve until the total emptying of the filter. Remove the screws on the top cover, and replace the filter insert cartridge.

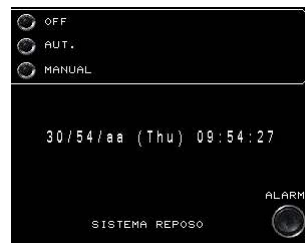

SECURITY

The filtering protocol will be affected in the following cases:

- If, for any reason, any of the pump supply to tank is started, filtration will be cancelled for ten minutes, prioritising the fuel supply to tanks.
If the system is operating manually. The filtering process is stopped, switching to automatic mode.
After that ten minutes of filtering cancellation, the system will resume the filtering protocol, only if it still remains within the programmed cycle time frame programmed (up to 59 minutes), as long as the start of fill pumps had ended.
- If the pressure increases to 3 bars, it stops until descending to 2 bars. A local alarm is displayed at the screen and remotely by mod-bus.
- The system detects a leak at its oil collecting tray infrared sensor. In this case, the system will be blocked and local alarm is displayed at the screen and remotely by mod-bus.
- In low level alarm at in main tanks or manhole leak detected.

The system, under automatic mode, will ignore any tank in alarm during the run cycle, until that alarm is solved. Under manual mode, it will also not allow the tank in alarm condition to start.

