

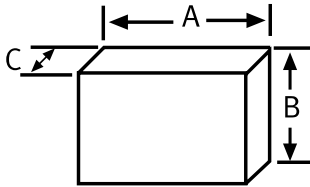

OIL TRANSFER PRESSURE UNITS

RL ONE PUMP - RL ZW TWO PUMPS

Ring Transfer for Diesel and HVO



MODEL N / ZW		RL 0	RL 1	RL 2	RL 3	RL 4	RL 5	RL 6	RL 7	RL 8	RL 9	RL 10
MAX. FLOW	l/h	100	260	460	900	1.400	2.100	3.400	5.300	7.500	10.500	12.000
SUPPLY FLOW	l/h	65	150	300	600	900	1.400	2.300	3.600	4.900	7.000	8.000
SUPPLY VOLTAGE	VOLT	400*	400	400	400	400	400	400	400	400	400	400
MOTOR POWER	KW	0,25	0,25	0,25	0,55	0,55	2,2	3	3	4	4	4
	C.V.	1/3	1/3	1/3	3/4	3/4	3	4	4	5,5	5,5	5,5
MOTOR	U/min-1	1.420	1.420	1.420	1.420	1.420	1.420	1.420	1.420	1.420	1.420	1.420
CONNECTION TO THE HYDRAULIC CIRCUIT (Ø THREAD / Ø MM)	SUCTION	1/2" iG DN 20	DN 20	DN 20	DN 25	DN 25	DN 32	DN 40	DN 40	DN 40	DN 40	DN 40
	DRIVE	1/2" iG DN 20	DN 20	DN 20	DN 25	DN 25	DN 32	DN 40	DN 40	DN 40	DN 40	DN 40
	OVERPRESSURE	1/2" iG	1/2" iG	1/2" iG	3/4" iG	1" iG	DN 32	DN 40	DN 40	DN 40	DN 40	DN 40
SECURITY VALVE OPEN AT:	bar	6,5	6,5	6,5	6,5	6,5	6,5	6,5	6,5	6,5	6,5	6,5
MAX. SUCTION	m	5	5	5	5	5	5	5	5	5	5	5
MOTOR PROTECTION	IP	55	55	55	55	55	55	55	55	55	55	55

(*) There is a 230 single-phase version (W)
- Threaded Flanges DIN 2566

MODEL	RL 0		RL 1		RL 2		RL 3		RL 4		RL 5		RL 6		RL 7		RL 8		RL 9		RL 10	
	N	ZW	N	ZW	N	ZW	N	ZW	N	ZW	N	ZW	N	ZW	N	ZW	N	ZW	N	ZW	N	ZW
A	595	870	595	870	595	870	870	890	870	890	1.200	1.300	1.200	1.300	1.200	1.300	1.200	1.300	1.200	1.300	1.200	1.300
B	575	720	575	720	575	720	720	790	720	790	1.000	1.000	1.000	1.000	1.000	1.000	1.100	1.100	1.100	1.100	1.100	1.100
C	240	300	240	300	240	300	300	350	300	400	500	850	500	850	500	850	500	850	500	850	500	850
APPROX. WEIGHT. (kg)	15	32	17	36	17	36	29	73	35	84	100	130	105	135	110	145	120	150	125	155	130	165

SUCTION DIAGRAM

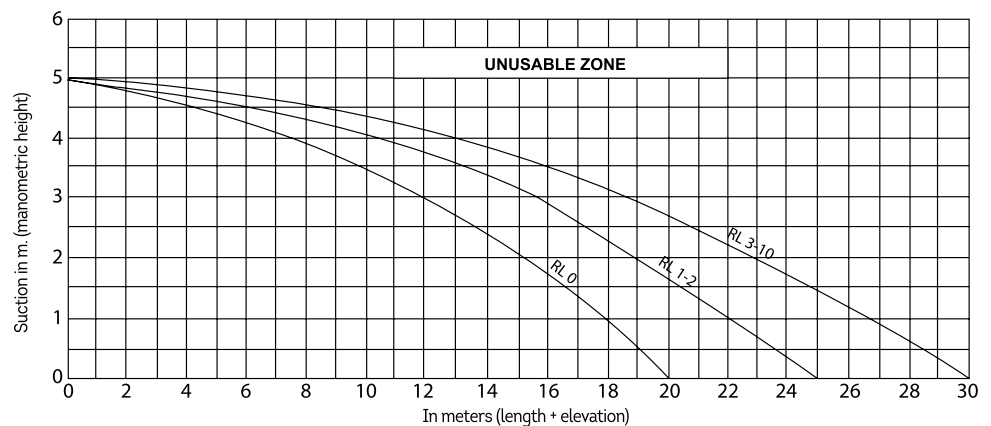

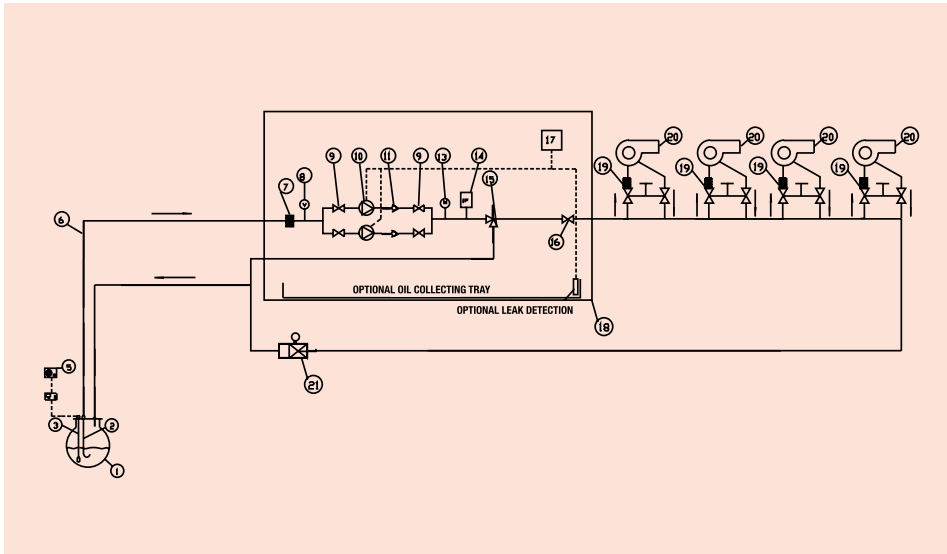

- 1) Main storage tank
- 2) Suction pipe
- 3) Level gauge probe
- 4) EDM-40 level gauge indicator
- 5) Overfill safety system
- 6) Intake pipe
- 7) Filter
- 8) Vacuum gauge
- 9) 4 Non-return valve
- 10) 2 Electric gear pumps
- 11) Pressure gauge
- 12) Low level pressure switch
- 13) Conducted escape safety valve
- 14) Quick shutoff valve
- 15) Electric control system with timer
- 16) Degassing bottle
- 17) Quick shutoff valve
- 18) Burner
- 19) Aluminium selfclean filter
- 20) Burner

Contents list for RL Transfer Ring System One Pump Versions

Motor, flange, clutch, coupling, gear pump, filter, vacuumeter, pressure gauge, pressure switch, security for pipe breaking or no fuel failure, motor protection with contactor, main switch, failure indicator, time delay pressure switch control for first runnings, overpressure security valve, flange or G inside tread connection to hydraulic circuit, free relay connections for failure signals out of the RL pump. All ready, mounted, fixed and electrically connected in wall plate. RL 5 and above in angle workframe.

Additionally, in Two Pumps versions:

Motor, flange, clutch, coupling, gear pump, Motor protection with contactor, alternating motor steering in time swap over. "IM" system to stop pumps when all burners are off is included (optional for RL-N).

Manufactured and tested under DIN 12.514-1 (except RL 30 BIO).

Motor, flange, clutch, coupling, gear pump, Motor protection with contactor, alternating motor steering in time swap over. "IM" system to stop pumps when all burners are off is included (optional for RL-one pump).

Special Non-Ferrous metal free versions upon request.

Reference mark:

To maintain security disposals from DIN norm, the pressure regulation valve must be placed in the return pipe to tank in proximity to the tank.

Accessories and adaptations

- IM system to stop pumps when all burners are off (optional for RL-N)
- Free voltage relay output to control from centralised Building Management System, in kit 3, 4 or 6 signals (2-thermal, motors 1 or 2 ON, low pressure and Leak safety ON).
- GSM alarm system by SMS messages, or connection to modem.
- Adaptation of Pressure Group for high pressure, working conditions of up to 6,5 Kg/cm²
- Leak collector trays with infrared detectors (standard in RL-4 and above).
- Modifications to adapt to specifically regulated environments (tropicalised equipment or ATEX.)
- Solenoid valves with flow limiters, to automate filling in supply tanks for electrical generators.
- Soundproof sheet cabinets with UNE-25 poly-pyramid foam and lock. Manufactured with no back and made-to-measure for each Pressure Group model.
- Assembly of Pressure Groups in IP-55 cabinets for outdoor installation with exterior suction and drive pipe couplings, electric connection presses and ventilation grills.
- Line pressure switch to signal low pressure.
- Power supply failure safety system (timer deferred low pressure stop.)



This is a product suitable for projects.
See all Inpro project references here



C/Invierno, 4-6 28500
Arganda del Rey, Madrid (Spain)
Telf.: (+34) 918 719 294
info@inprord.com
www.inprord.com



63457 Hanau - Voltastr, 10
Deutschland (Germany)
Telf.: (+49) 06181/9587-0
info@simka.de
www.simka.de