

PRESSURE UNITS

GP 30- 1500



Installation and Maintenance of the Pressure Units

Models: GP-30 N / GP-30 GE / GP-70 N / GP-70 GE / GP-130 N / GP-130 GE / GP-200 N / GP-200 GE / GP-300 N / GP-300 GE / GP-500 N / GP-500 GE / GP-800 N / GP-800 GE / GP-1500 N / GP-1500 GE / GC-N / GC-GE and all GP-M models

Original Manual



1. Introduction.....	4
2. Installation.....	5
3. Electric Connection Diagram	11
4. Technical Specifications	15
5. Commissioning.....	16
6. Controls.....	17
7. Indicators.....	19
8. Suction Height Limits & Distances.....	20
9. Piping Dimensions.....	21
10. Repair and Maintenance.....	22
11. Pressure Reducing for Fuel.....	26
12. Troubleshooting - Fault guide.....	27
13. Transport, Maintenance and Storage.....	28
14. Safety	29
15. Declaration of conformity	30
16. Inpro Guarantee.....	31

1. Introduction

DESCRIPTION OF INPRO GP PRESSURE UNITS

Inpro pressure units are a ready-made set of necessary appliances connected with one or two oil pumps in the way that provides appropriate parameters at the output guaranteeing a trouble-free work of the installation burners are equipment used to decant oil from a main reservoir at various points of consumption. These can be both phase power [W] as phase [T], compact, tested and assembled for final installation.

The entire pumpset consists of:

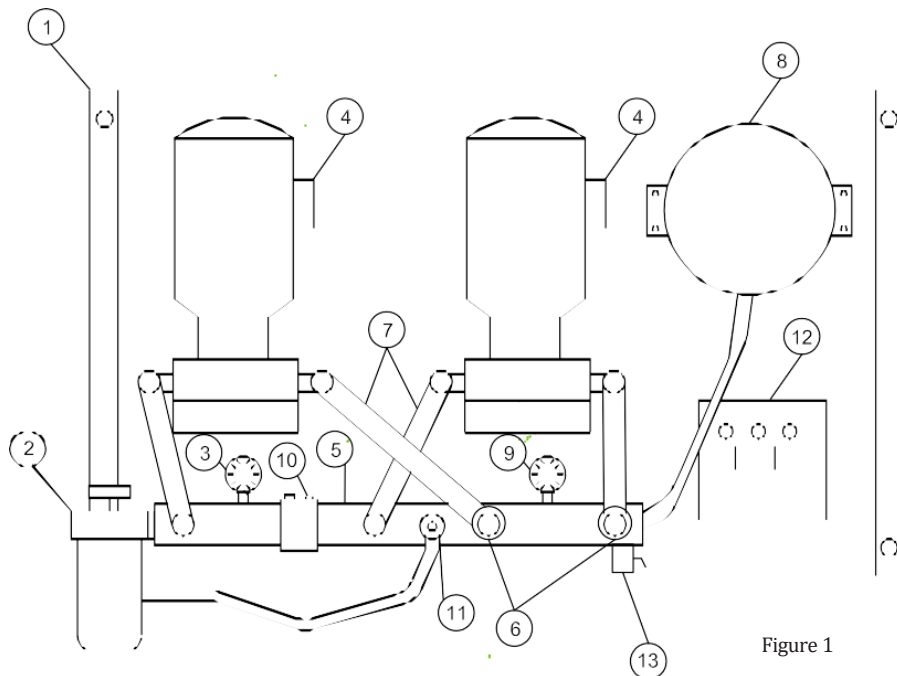

Figure 1

- | | |
|---------------------------------------|----------------------|
| 1. Bedplate | 7. Flexible Tubes |
| 2. Filter | 8. Expansion Vessel |
| 3. Vacuum Gauge | 9. Pressure Gauge |
| 4. Pump[s] [Single-N- or duplex -GE-] | 10. Pressure Switch |
| 5. Manifold | 11. Safety Valve |
| 6. Non-return Valves | 12. Electric Control |
| | 13. Ball Valve |

NOTE: The standard Inpro equipments are not designed or manufactured for use in potentially explosive atmospheres.

2. Installation

Installation and putting into operation shall be carried out by an specialised installation company.

The following shall be taken into account:

- It shall be installed on a smooth, dry, solid wall. In the case of high flow rate equipment, it is recommended that a solid bed be executed on the floor if necessary.
- The pressure equipment shall always remain in view and accessible.
- It shall be installed within the suction elevations (see page 20).
- Adequate protection shall be guaranteed in outside installations.
- Outside piping shall be protected with thermal insulation.
- The pressure equipment shall be installed well away from explosive atmospheres. For such areas see “Explosionproof equipment”.

Pressure equipment installation shall be executed as follows:

1. Secure the equipment to the wall, see table on page 6.
2. Execute electrical connects according to model, see pages 11-15.
3. Hydraulics connections

SUCTION PIPING CONNECTION

1. Connection of aspiration piping between the equipment (see Figure 1, Point 2) and the tank, employing copper piping (recommended) and compression connectors in order to guarantee good sealing.
2. It is recommended to use connectors 1-2-3 included according to Figure 2 and to include a shut-off valve at suction “A” (to isolate pressure equipment aspiration from the main tank).
3. The installation inside the tank is executed either by floating aspiration tube or employing intake piping with a 15-cm margin from the tank bottom, according the Figure 2.
4. A FOOT VALVE SHALL NOT BE INSTALLED, because the negative pressure loss would increase and impede fuel return in case of overpressure. The equipment comprises elements that prevent installation failure.

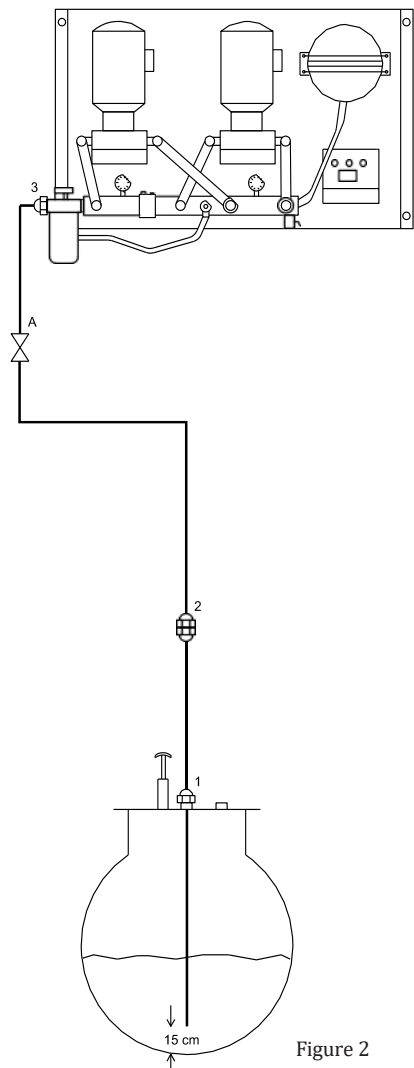

Figure 2

DRIVE SIDE PIPING CONNECTION

1. Connection of impulsion piping between the pressure equipment, *see Figure 1, Pont 13* and the consumption point using copper piping and include the necessary elements for feed the one or two-stage burners, *see page 7*, standby generators (tanks), *see page 7* or modulating burners, *see page 7*.

ANCHORING THE GROUP

MODEL	GP30	GP-70 GP-130 GP-200	GP-300	GP-500 GP-800	GP-70 GE GP-130 GE GP-200 GE	GP-300 GE	GP-500 GE GP-800 GE	GP-1500 GP-1500 GE	GP-GC
A	240	450	690	690	700	800	890	1.170 1.450	1.420
B	380	470	520	520	470	500	570	750	780
C	190	300	340	340	300	340	340	460	800
D	-	440	485	395	440	470	540	700	760
E	190	420	650	660	670	770	860	1.120	1.560

Avoid entry of water, or condensation forming in the housing in which it is intalled.

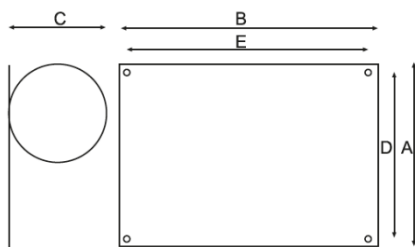

Dimensions for groups one and two pumps

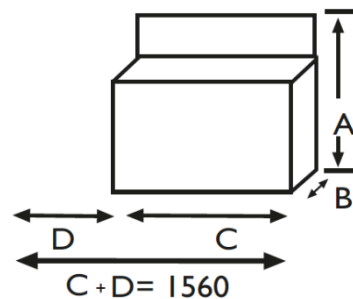

Dimensions of High Flow Units (GP GC)

GP OIL SUPPLY TO 4 BURNERS

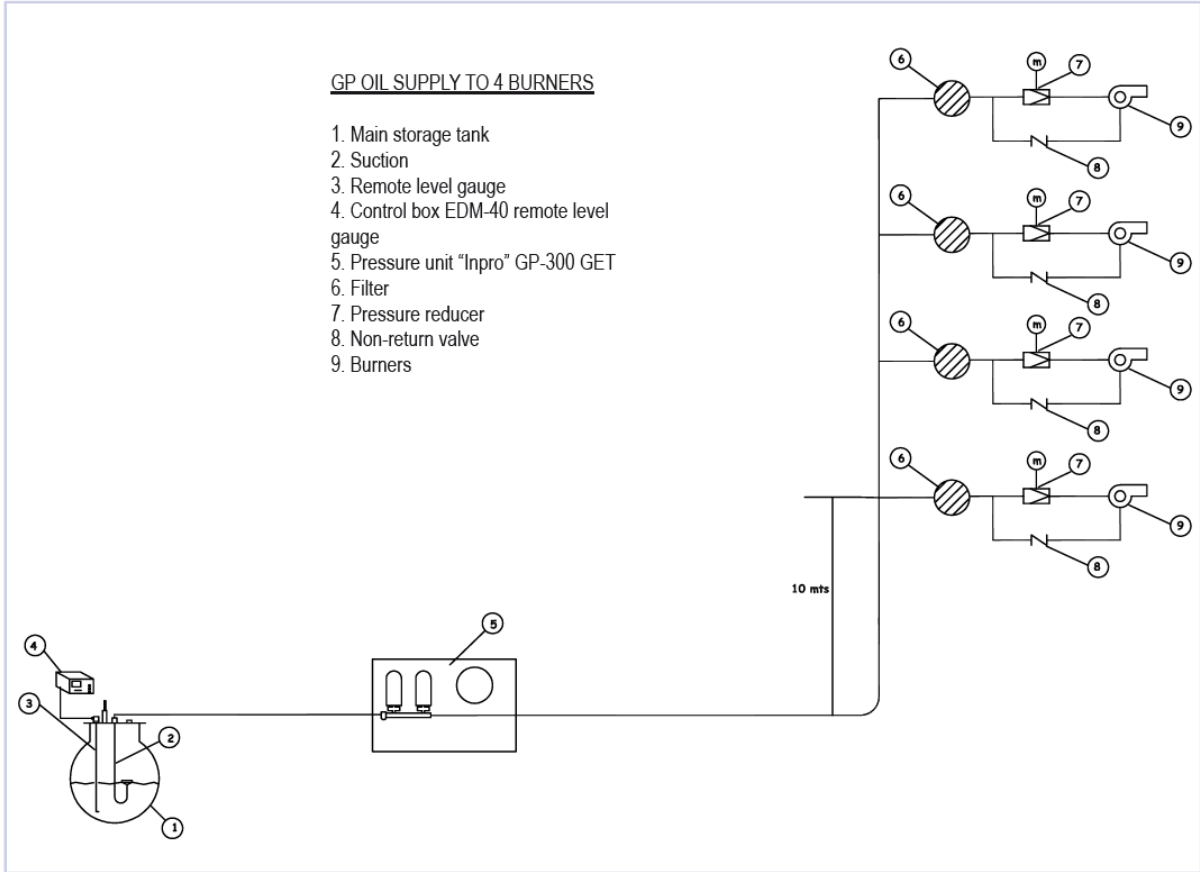

GP TO MODULATING BURNER

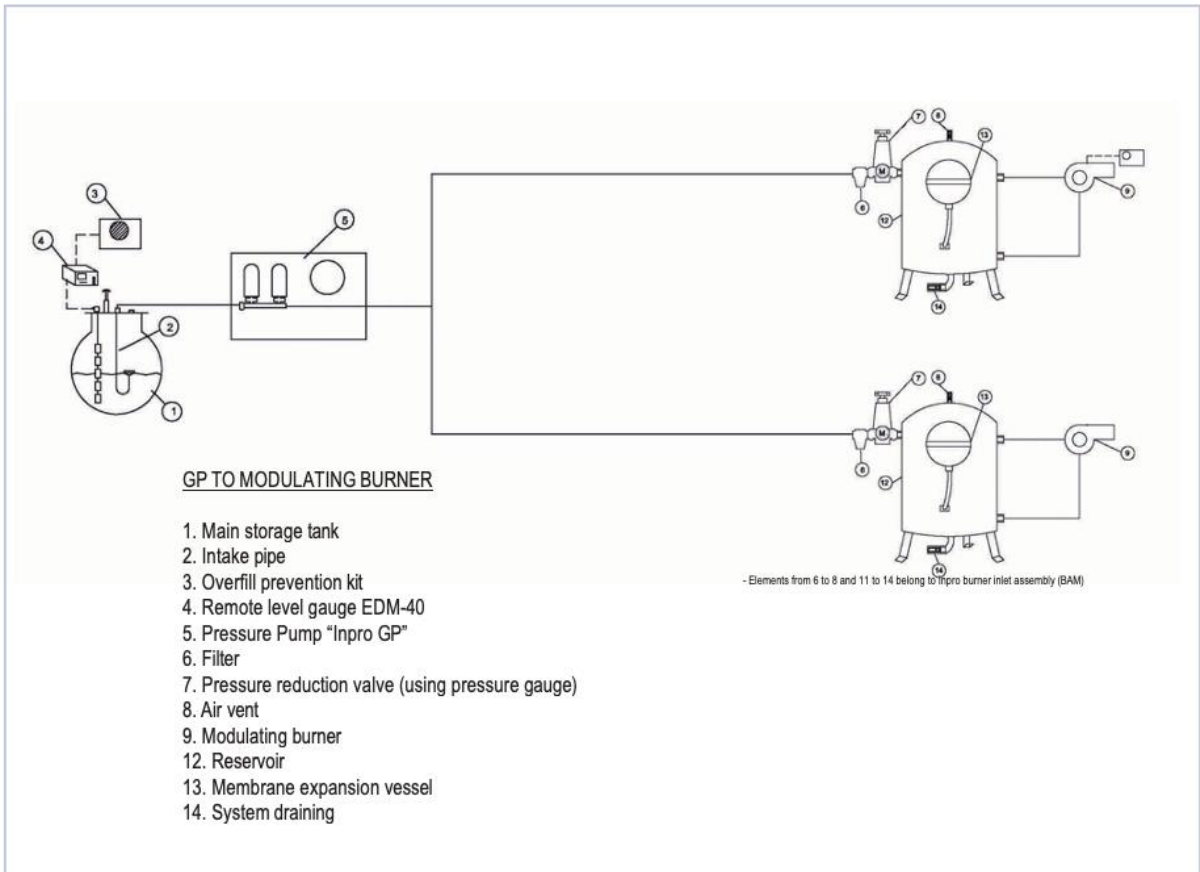

GP GE OIL SUPPLY TO A POWER GENERATOR

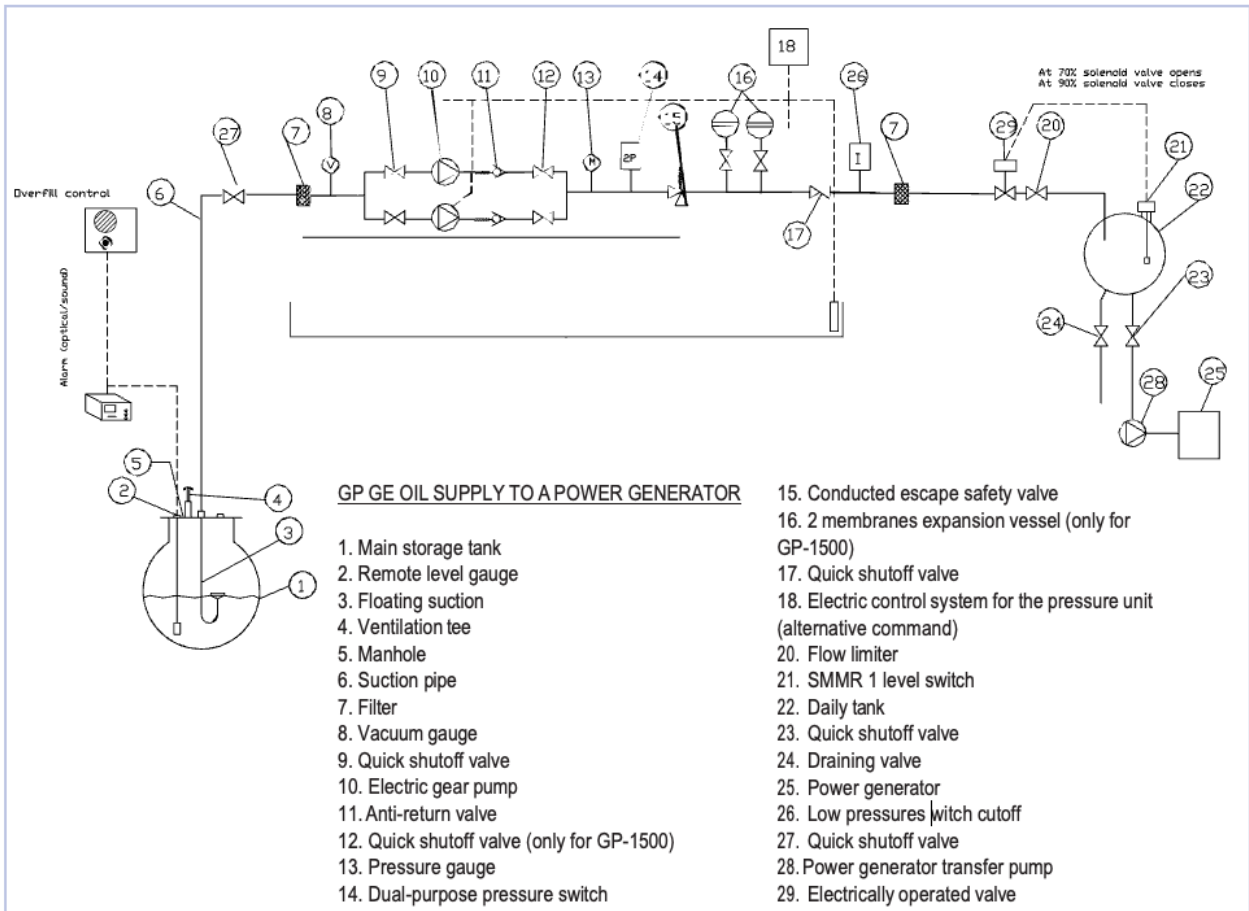

All of the units leave the factory set up to threephase 400 Volts operation WITH NEUTRAL. The coils of the contactors always operate on 230 V.

For threephase 230 Volts, it is necessary to change:

- a) Connect according to diagramm *Page 11* (connection bridge B and S) b) Adjust thermal relay according to Table (*Belows*)

Signals:

- Red warning light (Low Pressure) indicates low pressure blockage
- Red warning lights (Pump 1 and Pump 2) indicate that the thermal relay protecting to Motor 1 or Motor 2 has gone off

Operation:

- Switch on AUTO: Makes M1 and M2 both function alterately. If one of the motors breaks down, the other one runs constantly
- Switch on MANUAL: You put MP1 and MP2 in one position and another al will

MOTOR PROTECTION WITH ELECTRONIC FREQUENCY CONVERTER

Electronic at single-phase pump set may be connected to 230 V AC power supply.

Those models are equipped with protection for motor overload, engine short circuit, and communication engine failure.

TERMAL RELAY (motor protection)

This part leaves the factory set for 400 V operation (*See connection diagram page 11*). The unit is possible either to operate on 230/400 V.

If necessary for installing, to connect to 230 V (threephase), you must make the following changes:

- 1 st. Connect the motor as indicated on pages 10-11.
- 2 nd. Current according to diagram.
- 3 rd. Adjust the thermal relay according to chart: (*next page*)

TERMAL RELAY (motor protection)

GP-70	220 V	0,7
	380 V	MIN
GP-130	220 V	1,07
	380 V	MIN
GP-300	220 V	1,5
	380 V	MIN
GP-500	220 V	1,5
	380 V	MIN
GP-800	220 V	3,3
	380 V	MIN
GP-1500	220 V	4,7
	380 V	MIN

3. Electric Connection Diagram

380 / 400 V. Tri-phase with neutral

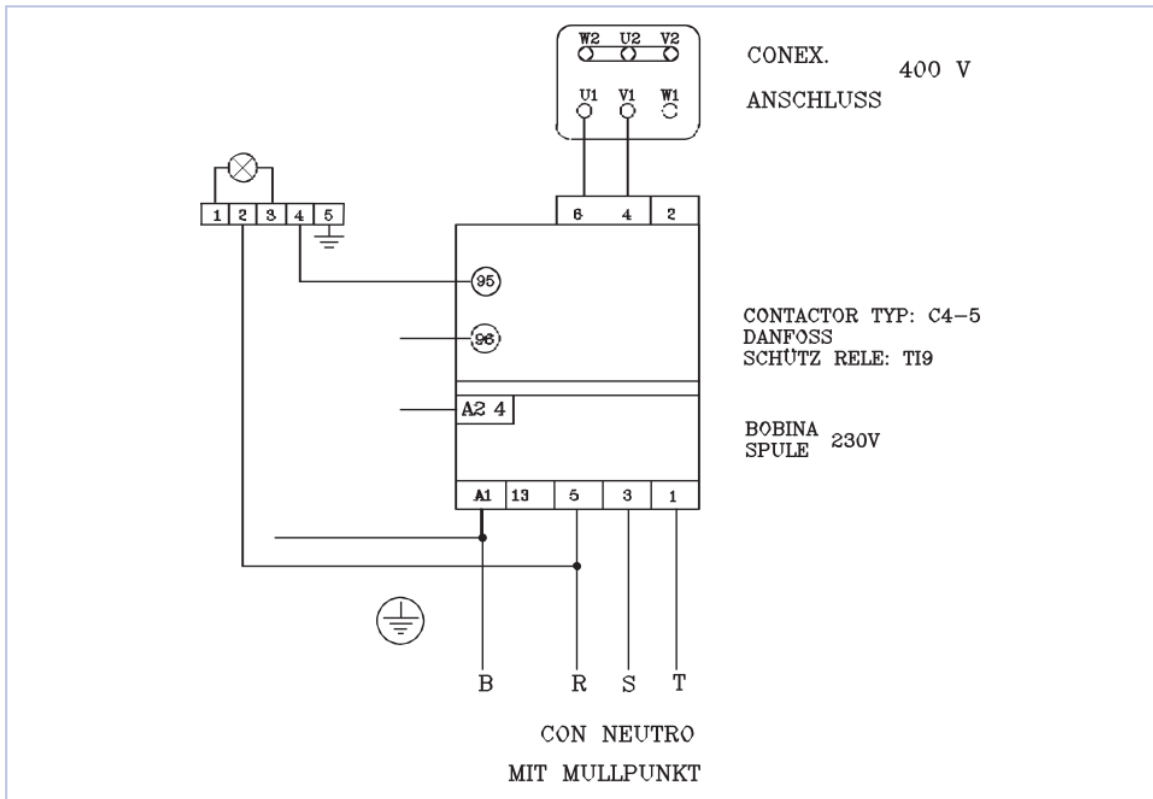

230 V. Tri-phase

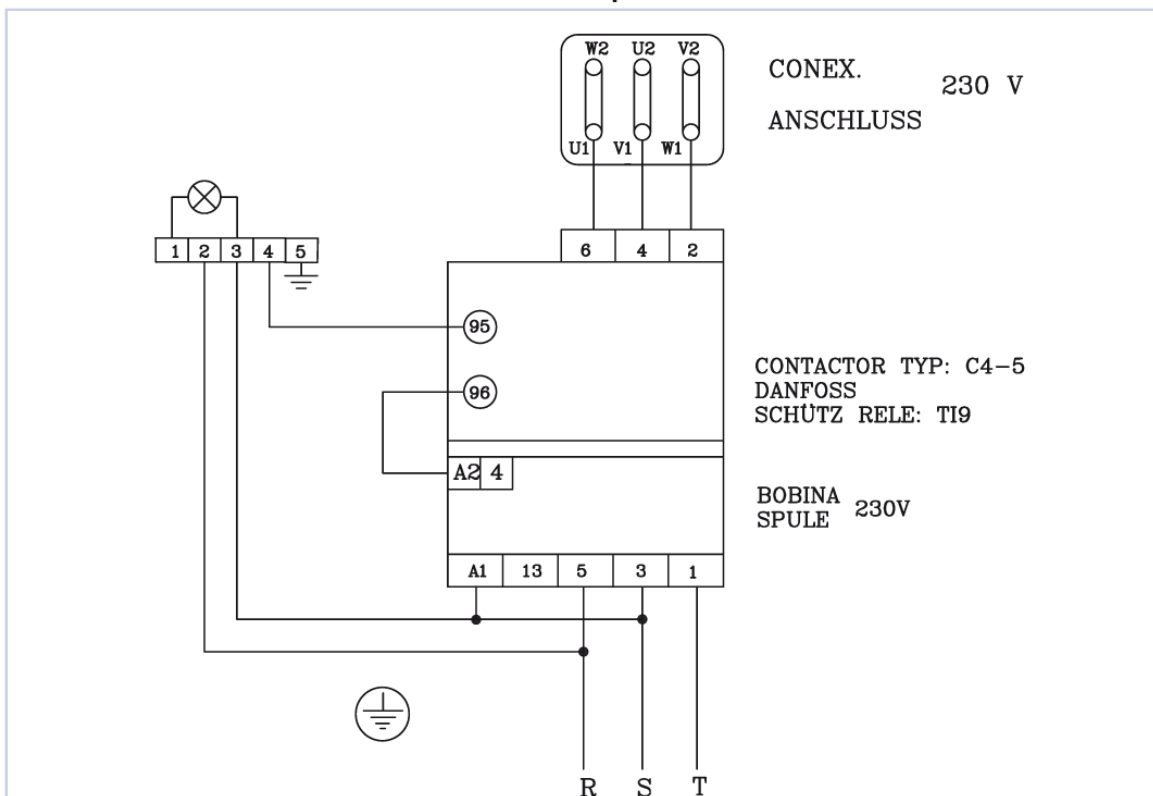

230 V. Single-phase with frequency converter to Tri-phase

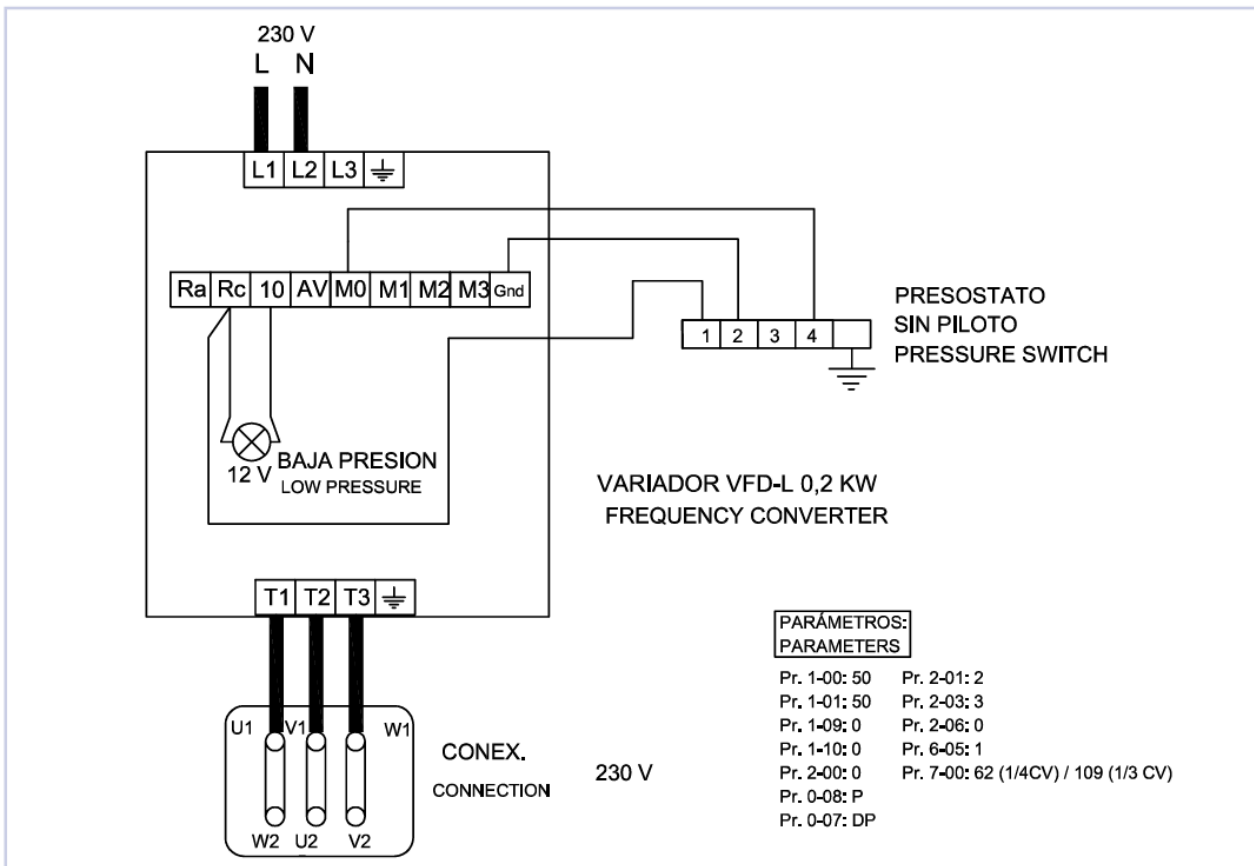

GC/NT High Flow Systems

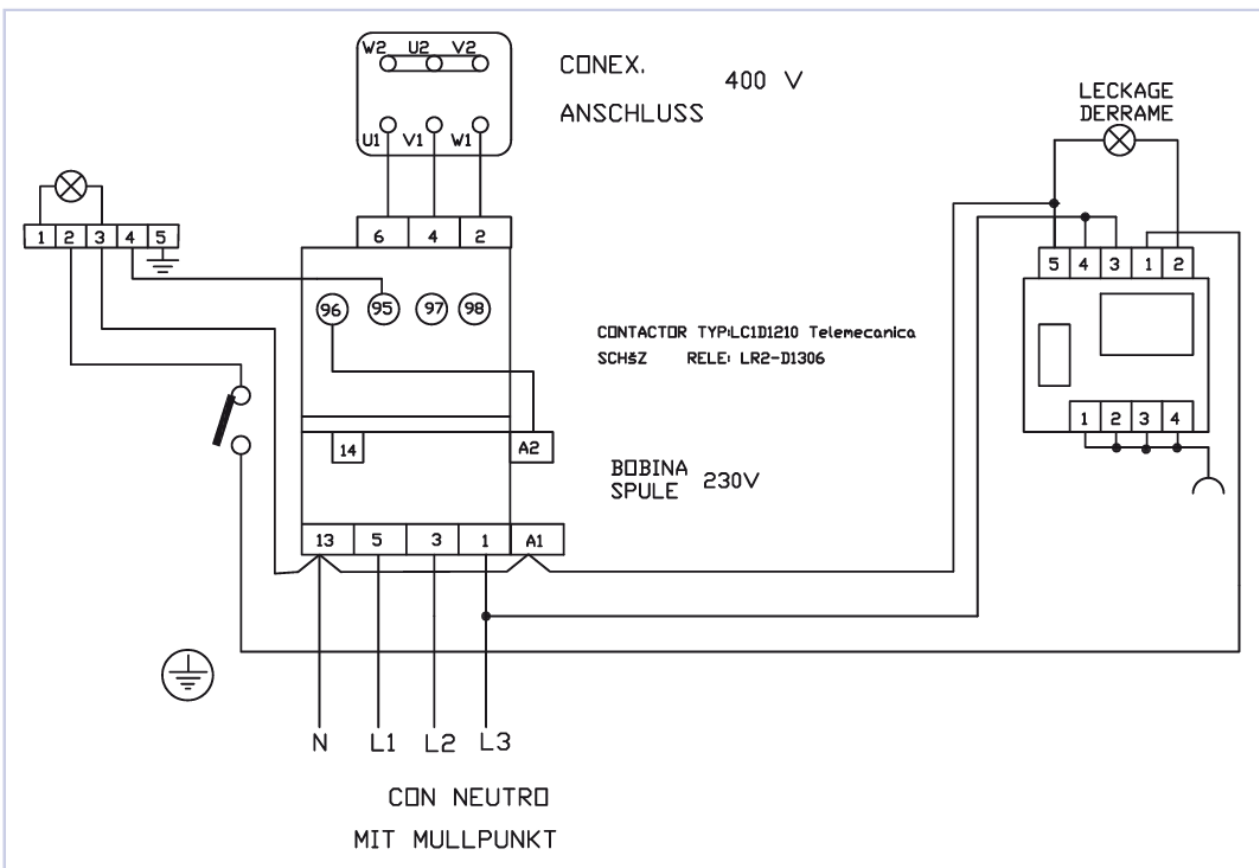

GC/GE High Flow Systems

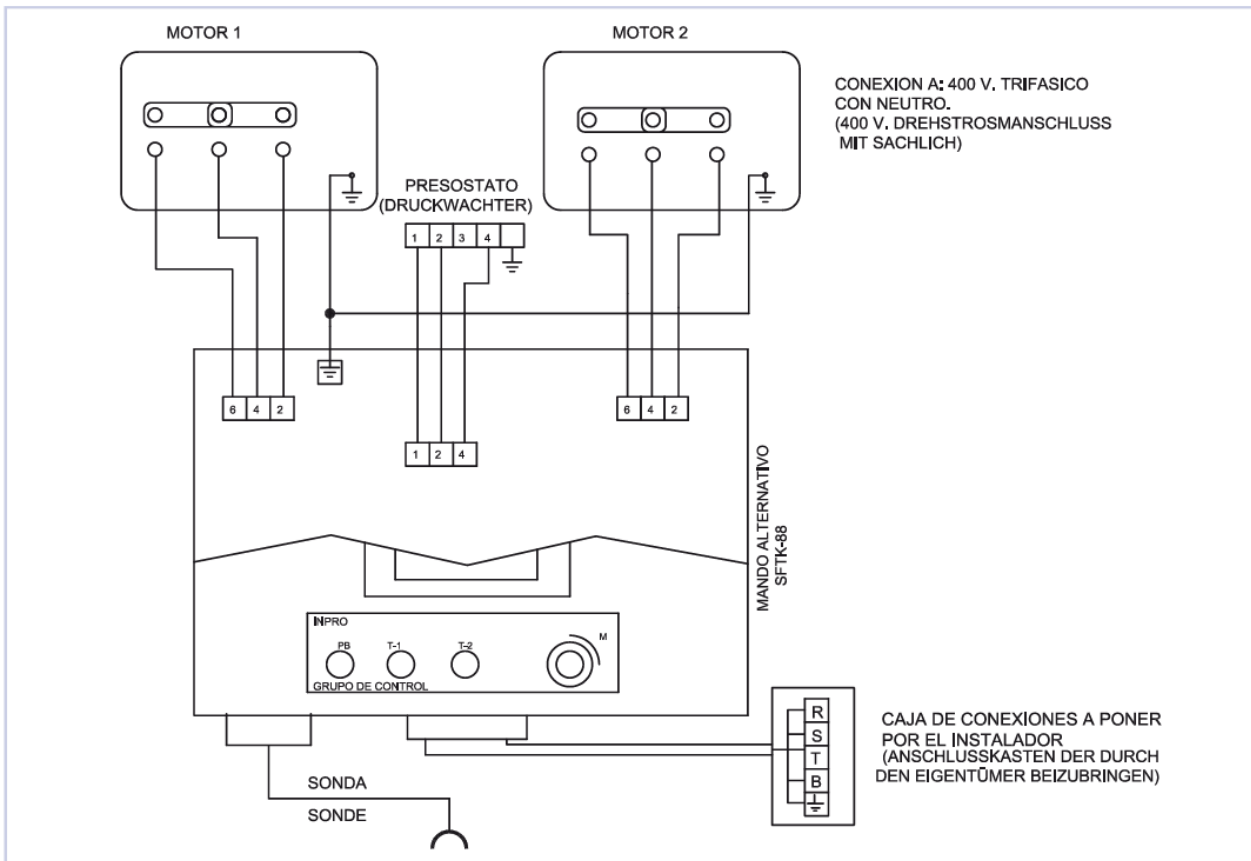

400 V. Tri-phase without Leak Detector

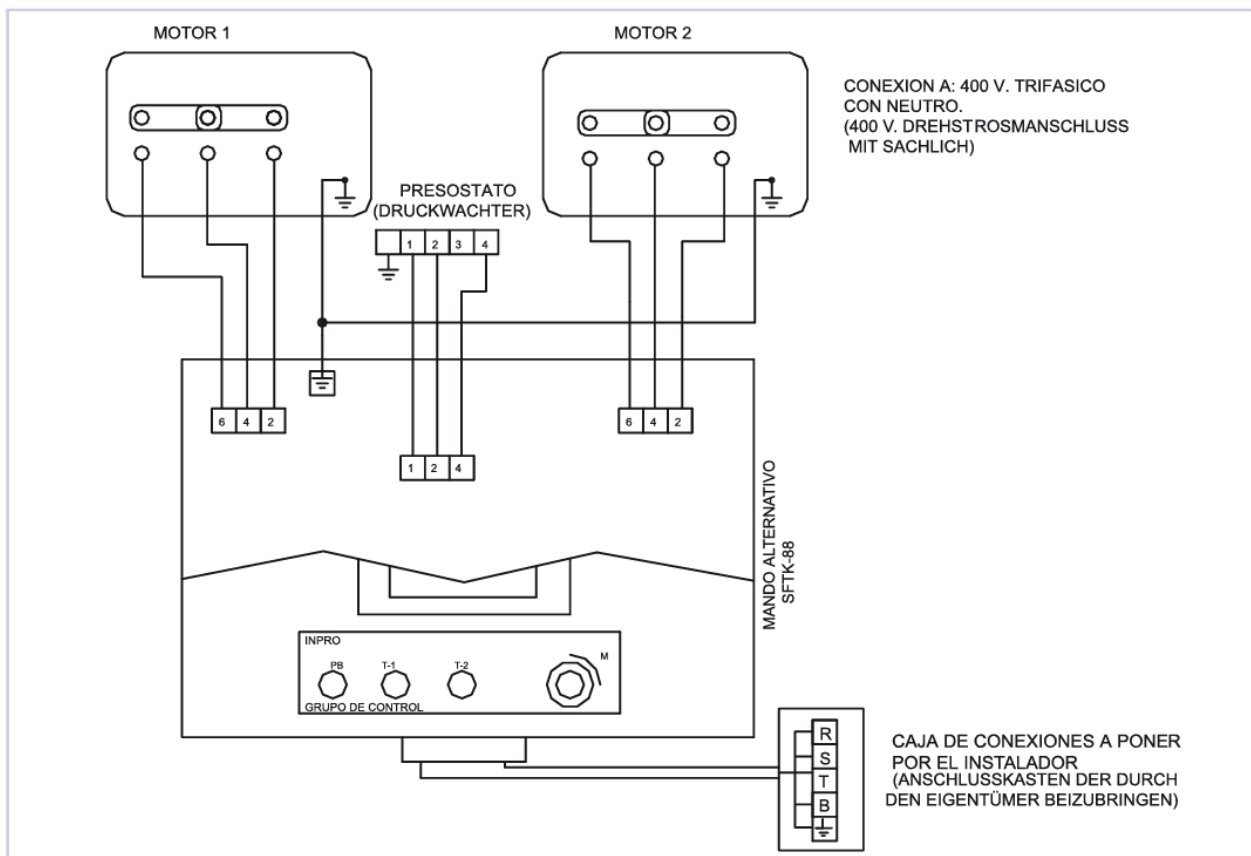

230 V. Tri-phase without Neutral

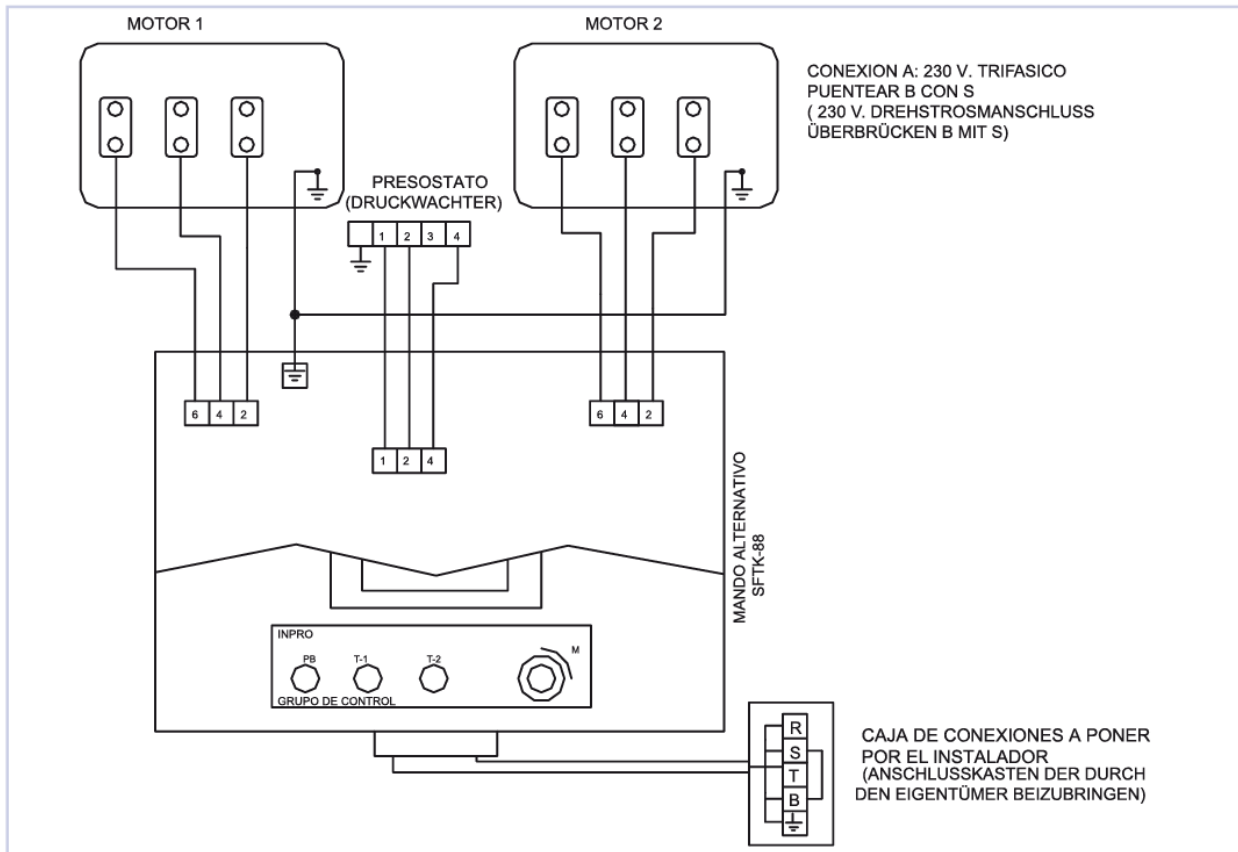

230 V. Single-phase with frequency converter

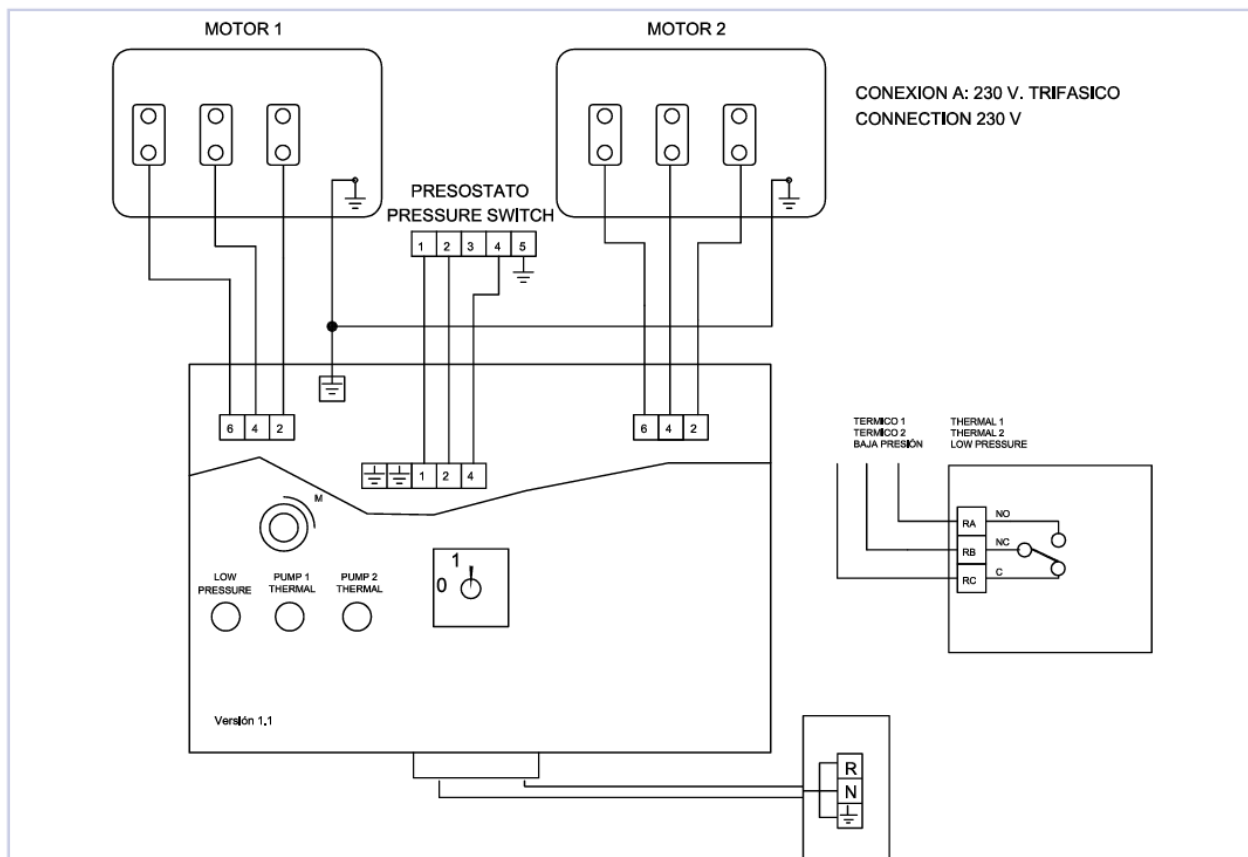

4. Technical Specifications

MODEL	FLOW	CONNECTION TO THE HYDRAULIC CIRCUIT (ØTHREAD / Ø mm)		POWER SUPPLY	CONSUMPTION	MOTOR POWER	MAX PRESSURE	SAFETY VALVE OPENS AT:	APPROX. WEIGHT (kg)	
		SUCTION	DRIVE	VOLTS		C.V.			kg/cm ²	kg/cm ²
GP-30	30	10	3/8"	230 monophase	1,38	1,8	3,5	4	6,4	21
GP-70	70	1/2"	3/8"	230/400 tri-phase (*)	0,9 / 0,43	1/4	3,5	4	18,2	31,4
GP-130	130	1/2"	3/8"	230/400 tri-phase (*)	1,70 / 0,98	1/3	3,5	4	21,8	34,4
GP-200	200	1/2"	3/8"	230/400 tri-phase (*)	1,70 / 0,98	1/3	3,5	4	21,8	35,8
GP-300	300	3/4"	1/2"	230/400 tri-phase (*)	1,75 / 0,9	1/2	4	6,5	31,2	43,4
GP-500	500	3/4"	1/2"	230/400 tri-phase	1,75 / 0,9	1/2	4	6,5	33,6	53
GP-800	800	1"	1/2"	230/400 tri-phase	2,5 / 1,5	3/4	4	6,5	36	89
GP-1500	1.500	1"	3/4"	230/400 trifásico	4,5 / 2,8	1 1/2	4	6,5	89	135
GP-2200	2.200	1"	3/4"	230/400 tri-phase	6 / 3,45	2	4	6,5	99	117
GP-3200	3.200	Flange DN-40 Thread 1 1/2"	Flange DN-25 Thread 3/4"	230/400 tri-phase	6 / 3,45	2	4	6,5	105	127
GP-4200	4.200	Flange DN-40 Thread 1 1/2"	Flange DN-25 Thread 1"	230/400 tri-phase	8 / 5,4	3	4	6,5	110	136
GP-6500	6.500	Flange DN-50 Thread 2"	Flange DN-40 Thread 1 1/2"	230/400 tri-phase	10 / 7	4	4	6,5	120	147
GP-8500	8.500	Flange DN-50 Thread 2"	Flange DN-40 Thread 1 1/2"	230/400 tri-phase	10 / 7	4	4	6,5	135	164
GP-12000	12.000	Flange DN-40 Thread 2"	Flange DN-50 Thread 2"	230/400 tri-phase	13 / 9	5,5	4	6,5	140	171

(*) There is a 230 single-phase version (W)

- Motor Ingress Protection Rating: IP55(except at GP-30 N and GE, which is IP 20)

5. Commissioning

The implementation must be performed by an installation company.



1. Pressure Switch light on.

CHECK

1. Check the direction pump is rotating (tri-phase)
2. Discharge valve open
3. Purge airvalve or disconnect flexible pipe next to burner, purging the entire system of air.
4. Press pressure switch button, which will start the pump, until you hear a change in the noise (indicating entry of fuel). Immediately close discharge valve and continue pressing button until the pressure regulator light goes out.
5. Once the light turn off, it will continue operating automatically until the maximun set pressure is reached, which will stop the motor.

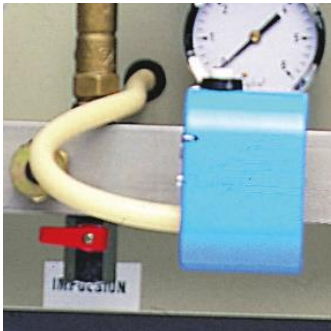

Immediately open the discharge valve slowly and the fuel will run out, purging the air from the discharge pipe, which will flow out through the open vent cock. The discharge pipe now being full of fuel and having no air makes it possible to start the appliance.

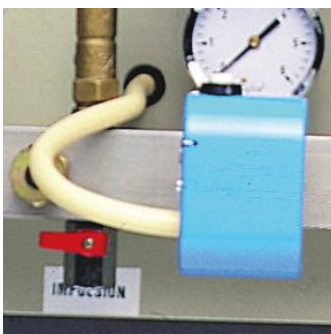

6. Controls

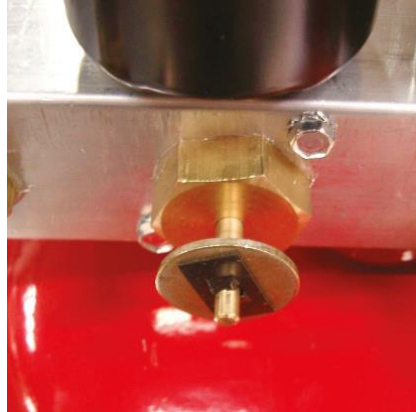

SAFETY VALVE

Has two functions:

A: Empty the drive system in the tank manually or by excess pressure.

B: Prevent any possible break downs due to excess pressure.

Safety valve opens at:

- 4 kg/cm²: GP-30, 70, 130 y 200

- 4,5 kg/cm²: GP-300, 500, 800, 1500 and GC

Manually opening:

- Model 4 bar: Pulling

- Model 4,5 bar: Turning



PRESSURE SWITCH

Comprising of two microswitches, each having two contact positions.

Comes set to work with an operating range which includes the positions from approximately 1,6 bar to 2,8 bar.

Emergency stop or contact will begin drop at 0,8 / 1,2 bar.

If more pressure is needed for any reason, merely adjust the pressure adjusting nut.

- To increase work pressure.
- To lower work pressure.

In case of pressure drop check for blockage before pressure gauge reaches "0".

7. Indicators

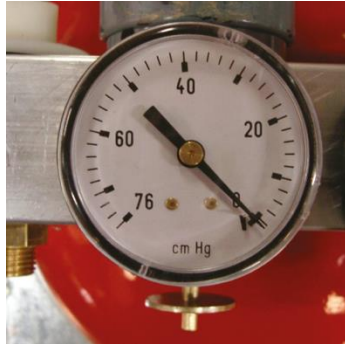

VACUUM GAUGE

This gauge indicates any problems arising in the suction system (vacuum side) when there is an air leak. If there is an air leak while the pump stops, the needle goes down to zero.

If the air leak is quite small, it will take longer (that is, it will go down very slowly, taking 1 or 2 hours or longer).

If there is blockage in this suction side, it will register a high reading (50-55 cm/Hg), indicating:

- Suction pipe blocked.
- Existing footvalve or valve shut or another mechanical problem.
- Dirty filter.

If, while the motor is running, the needle points to "0" and there is no suction:

- Fuel required.
- There is a large air intake.
- Pump dried up (prime and lubricate it).



PRESSURE GAUGE

Showing the pressure in discharge pipe.

If the motor pump runs but, however, registers "0":

- You have not purged the discharge line (purge).
- There is a large leak due to fracture of discharge pipe.
- Or the pump is not sucking.

8.Suction Height Limits & Distances

SUCTION LIMITS FOR INPRO GP-30/GP-1500

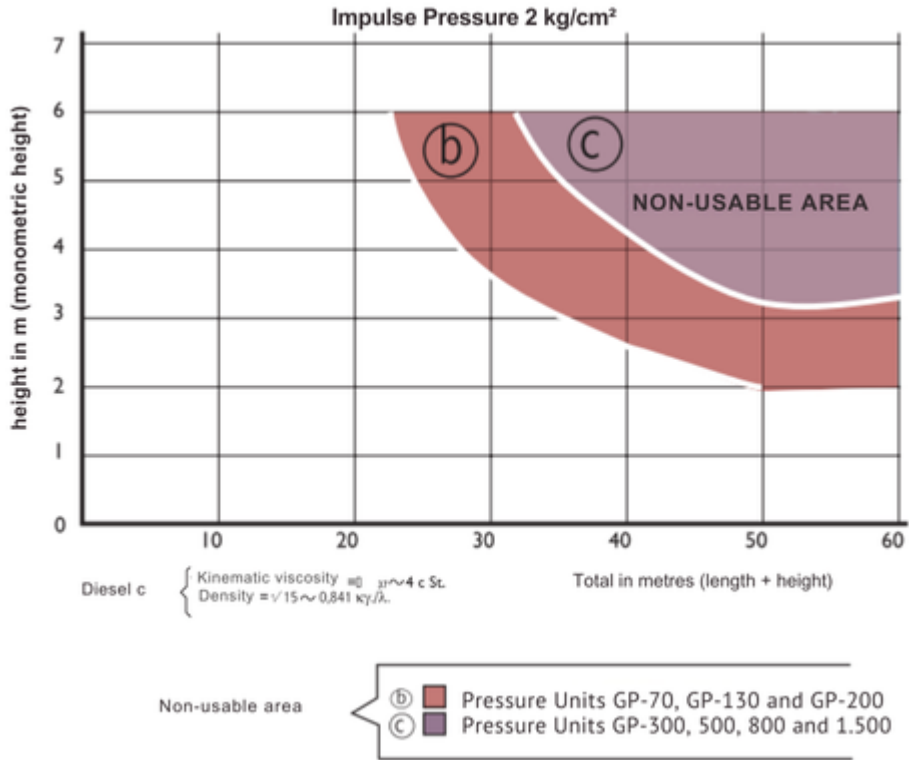

PRESSURE GROUPS GP-GC HIGH FOWS 2200-12000 I/h

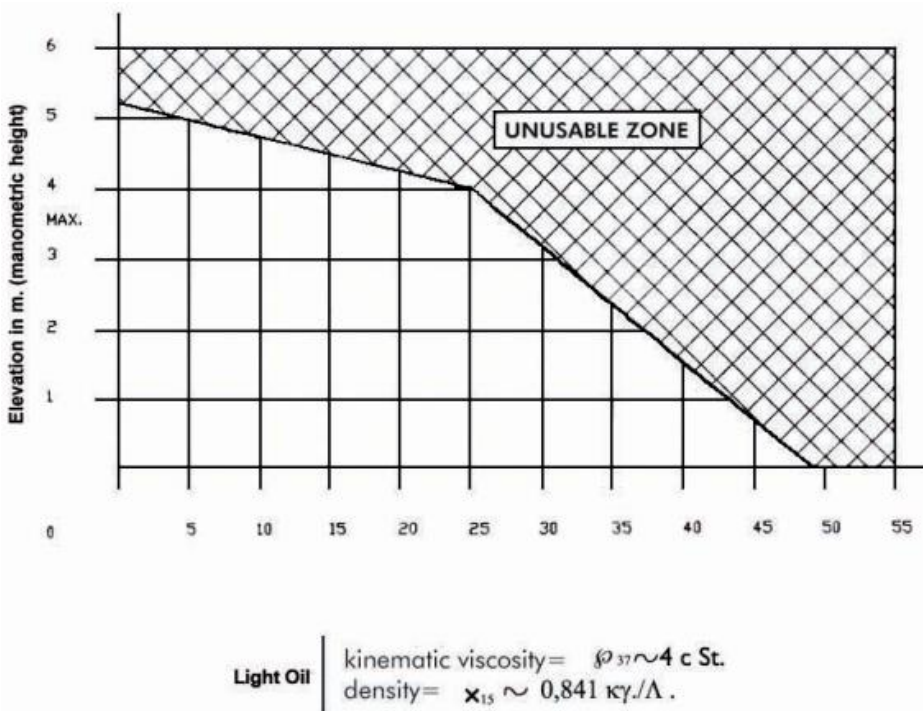

9. Piping Dimensions (inside diameters in mm)

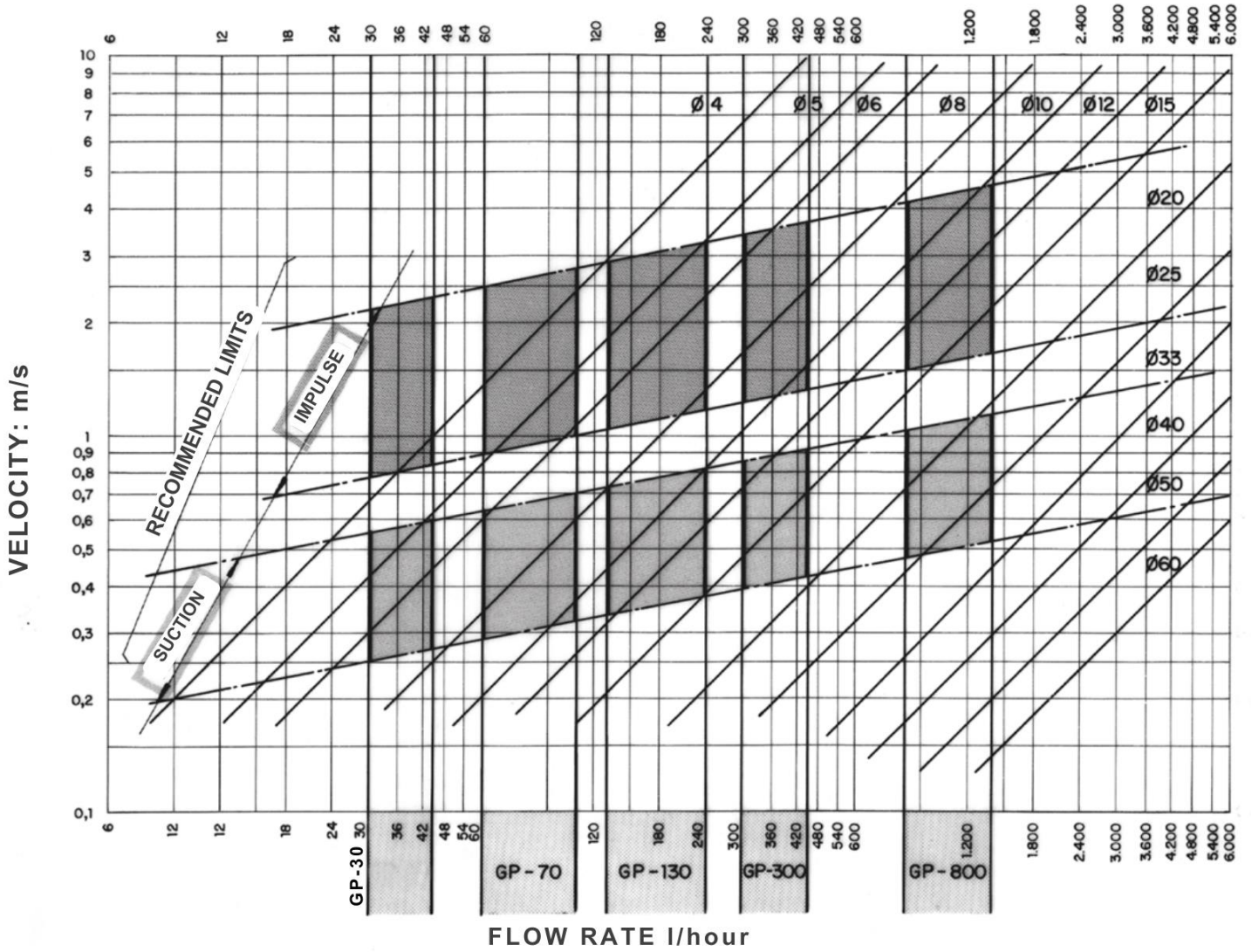

10. Repair and Maintenance

FILTER

When the vacuum guage registers higher normal, clean filter element or turn the handle several times if it is selfcleaning. Clean regularly -once a year-. It is important, when disassembling or assembling, to be certain that the seals are correctly positioned (A little oil helps). If any damage in the material is detected, replace. Tools: Set fixed open-end wrenches-Oil-can. Spare Parts: Filter Elements-Screws-Nuts-O-Rings-Plastic Cup and Complete Filters.

EXPANSION TANK

Whenever the system is inspected, check nitrogen pressure (It must range from 0,7 to 0,8 bar). Inspect at least every 2-3 months. When you see that the unit is starting and stopping almost constantly, it has lost its nitrogen. (Pump air in to achieve suitable pressure or excess pressure).

Check:

Tools: Pressure Gauge-Wrench-Diestock-Pump to inject air. Spare Parts: Complete Expansion Tank (Mode-S)-Capsule-Cap.

PRESSURE REGULATOR

Check setting (the set screws leave the factory set and sealed). If adjustment were necessary reseal.

Do not try to repair while in place. (Replace and repair in shop).

Tools: Screwdrivers-Ratchet handle wrench. Fixed open-end wrenches Nos. 7 and 8.

Spare Parts: Complete Pressure Regulator Neon Pilot Light-Button-Straight 10 x 3/8 Sambra Adapter.

FLEXIBLE PIPES

Requiring no special maintenance. However, because they are made of nitrile rubber, it is best to replace them after 5 - 6 years os use.

NOT CORRECT



CORRECT

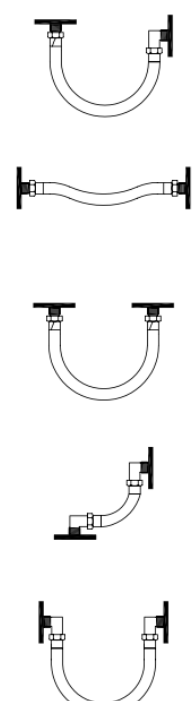

PUMP

If it has dried out (from running on empty, with water, etc.), inject oil in the intake while pressing the pressure regulator button on and off until the gears are covered in oil. (If this does not work, replace it).

We recommend that the shaft lip seal ring be replaced in the workshop when necessary (air leak).

Tools: Set of fixed open-end wrenches Nos. 6 to 15 Oil-can. (Regular grade oil).

Spare Parts: Pumps equipped with set of adapters.

CONNECTION (CLUTH)

During periodic inspection (3 months).

Check: Friction pins and clamp (Nylon Type) and rubber plugs and set place (Disc Type).

Tools: Set of ALLEN wrenches Nos. 2,5 to 6 Medium screwdriver. Spare Parts: Clutch spring - Nylon set (Model GP-70, 130, 500). Motor Disc Pump disc, rubber plugs washers.

MOTOR

If the paints is tan-colored, this means this means that it is overheating when in operation. The excessive heat indicates that the motor is running irregularly.

A) Check the phase consumption (the 3 must be the same).

B) If it is making noises: Inspect bearings, cheking to see if there is any friction. In these cases replace. We recommend that the repairs be made in the workshop.

Tools: Universal meter, set of screwdrivers. No. 7 box wrench. Set fixed open-end wrench.

Spare parts: Complete motor, fan turbine.

CHECK VALVE

Some dirt build up may accumulate, leading to the seat not closing properly. The way to eliminate this buildup without disassemble is by loosening the runner. If this is not possible, replace it . (Remove it by heating the base, being careful not to burn other parts).

Tools: Set fixed open-end wrenches Nos. 14-26. Plumber's torch (Butane).

Spare Parts: Valves, all Models.

SAFETY VALVE

For Models GP-30, 70 and 130, replace every 5-6 years (rubber tubing wears out) if there is any leakage, dripping or air intake.

1 st. Try to fix by replacing joints.

2 nd. Replace entire unit.

Tools: Set of fixed open-end wrenches Nos. 16-26.

Spare Parts:

Set of joints (O-rings and Flat).

Complete Safety Valve (30-70-130)

Complete Safety Valve (300-600)

Complete Safety Valve (800-1500)

MOTOR PROTECTION WITH MAGNETIC STARTER

If it seems to be well-worn due to inclement weather conditions (quite rusty), replace entire unit.

If it does not run, even though it is receiving current:

a) Reset relay

b) Check for continuity

c) Check coil

In any case, when there is a breakdown: REPLACE

If there is a breakdown in the alternative control of a "GE" group, replace the alternative control and send it to the factory for repair.

Tools: Multimeter - Assorted screwdrivers. Box wrenches Nos. 4-10.

Spare Parts: Coil (22 and 360) thermal relays in different ranges (*see pag. 10*), magnetic starter, housing, complete motor protection (GP-N), complete alternative control (GP-GE).

MOTOR PROTECTION WITH ELECTRONIC FREQUENCY CONVERTER

If not acting, switch off and on again.

If still it would not work and shows alarm at the pump set, please contact the technical service.

PRESSURE AND VACCUM GAUGES

These parts require no maintenance. In the case of a breakdown, they must be replaced.

Tools: Butane gas torch - No. 14 fixed open-end wrench. Spare Parts: Pressure-vaccum gauge 53 and 63 bar.

Other Spare Parts: Sambra nuts and rings for 10 and 15 diam pipe.

OTHER PROBLEMS

1. The pump turns but has no suction:
 - Air has entered the suction area (Necessary to purge).
 - There is no fuel in the tank.
 - It has dried out by running on empty (Prime and lubricate pump).
 - Check the rotation of the motor pump, if it turns in the right direction.
2. The motor turns, but the pump doesn't:
 - Check clutch spring or coupling.
3. No suction:
 - When the vacuum gauge either shows nothing at all or has registered a vacuum and has stopped (Air leak or pump dried by running on empty)
4. The motor does not run:
 - Is the voltage right?
 - Is the warning light indicating low pressure on?
 - If you press the button, does motor start?
 - Inspect wiring. Check pressure regulator setting.
 - Has the Thermal Relay triggered? Reset.
5. The motor runs on pressing the button but...
 - The pressure gauge is on "0" and the pilot light is off (either the light has failed, or the pressure switch regulation is not correct).
 - If the warning light has burnt out, the motor runs when the button is pressed.
 - If the pressure control is out of order, the motor runs without pressing the button.

11. Pressure Reducing for Fuel



FLOW T/h	MAXIMUM INLET PRESSURE	REGULATION	CONNECTION	ACCESORIES
15	6 kg/cm ²	Adjustable 0,2-3,5 kg/cm ²	For 8 mm tube	Locked box, filter and quick shutoff valve
20	6 kg/cm ²	Fixed outlet 0,1 kg/cm ²	For 8 mm tube	
20	6 kg/cm ²	Fixed outlet 0,1 kg/cm ²	For 10 mm tube	
200	6 kg/cm ²	Adjustable 0,2-3,5 kg/cm ²	Female 1/4"	With manometer
500	6 kg/cm ²	Adjustable 0,2-3,5 kg/cm ²	Female 3/8"	With manometer
1.500	6 kg/cm ²	Adjustable 0,2-3,5 kg/cm ²	Female 1/2"	With manometer
3.000	6 kg/cm ²	Adjustable 0,2-3,5 kg/cm ²	Female 1"	With manometer

12. Troubleshooting - Fault guide

	SYMPTOMS	FAULTS	OPERATION	OBSERVATIONS
1	Vacuum gauge indicates higher than normal	Blocked filter	Clean filter	Correctly place suitable seals. Replace in case of doubt
2	Rapid start-up and shutdown	Lack or excess of air in expansion tank	Measure air in expansion tank without any pressure in the unit	If diesel oil is coming out of the tank air chamber, replace the tank. Leave the expansion tank air pressure at one third that of operation
3	Drop in vacuum meter indication during equipment shutdowns of more than two hours	Air entering during piping or unit aspiration	Find where air is entering aspiration area	Pressurise aspiration piping and look for leaks
4	Fall in manometer reading without any flow to the consumption point	Dirty check valve	Clean check-valve closing, if problem persists, replace valve	Release the impulsion hose with pressure in the system, if the check valve leaks it is not closing correctly
		Open safety valve	Clean check-valve closing, if problem persists, replace valve	If the check valve does not leak and the impulsion valve is closed and the pressure drops, the safety valve is not closing correctly
		Leak somewhere in impulsion	Find where diesel oil is leaking due to impulsion	Repair or replace the point in poor condition
5	The pump turns, but the unit does not suck	Air has entered in aspiration area	See Point 3	
		No diesel oil in tank	Fill tank	Start the unit up
		The pump has run dry	Lubricate the pump with hydraulic oil	Oil the pump aspiration and switch on until it is correctly lubricated
6	Neither the pump nor the motor are running, but electrical power is reaching the motor	Burnt-out motor or bearing in poor condition	Replace motor	Switch off the pump and check whether the motor operates off-load
		Pump has seized	Replace pump	The pump may have dried out because it has been operating a long time off-load, this could be due to Point 3 or because the pump is dirty or is sucking water (fit floating aspiration and see Point 1)
7	The motor is running, but the pump is not	Incorrect motor-pump coupling	Repair, adjust or replace coupling	It is quite possible that this problem is caused by a dried out pump, see Point 6

13. Transport, Maintenance and Storage

WARNING

- Inadequate transport could damage the equipment.
- Do not throw or drop the equipment because this could cause injuries or damage.
- The equipments shall be protected from water, humidity, dust and dirt during transport.
- Condensation could affect sealed areas, metal components and electrical operation.
- Inpro S.L. pressure equipment has noise levels of less than 70 dB (A).

WEIGHTS

MODEL	GP-30	GP-70	GP-130	GP-200	GP-300	GP-500	GP-800	GP-1500	GP-GC
Approximate weight in kg for N	6,4	15	16	18	28.5	35	61	84	220
Approximate weight in kg for GE	21	27 21	30	33	46	50	83	140	289

14. Safety

Prior to performing any operation that involves handling chemical products (diesel oil, etc.), the safety and hygiene recommendations of the manufacturer in its safety file or on its package label shall be strictly followed.

1. The equipment installation, service, maintenance and inspection personnel shall be fully qualified to carry out this type of work.
2. The equipment shall be maintained in safe operating conditions at all times and shall be inspected at regular intervals with respect to operability by personnel fully trained in Inpro S.L. with respect to training requirements.
3. The equipment shall not be employed for any purpose other than that for which it was designed.
4. Spare parts that are not recommended and supplied by Inpro S.L. shall not be employed.
5. Any equipment modification by the customer shall be exclusive responsibility of said customer. Inpro S.L. will provide advice on any presented modification.
6. All safety legislation, together with the safety instruction cited in this manual shall be taken into account to provide greater protection.
7. The omission of the safety instructions in this manual could lead to personal injury and damaged equipment.
8. Before attempting any repair or replacement of parts, the line pressure shall be removed and the equipment completely disconnected from the main supply.
9. Operating conditions and the limits stipulated in this manual shall not be exceeded under any circumstances.
10. It is recommended to have adequate fire-extinguishing means available at the pressure equipment location.
11. It is also recommended that protection against indirect contact (earth leakage breakers) and maximum current (automatic overload breakers) be fitted to the installation.
12. The location shall be well-ventilated.
13. The following action shall be taken in case of accidental spill: Shutdown the equipment. Remove any sources of ignition. Read the diesel oil safety sheet, provided by the supplier, which contains guidelines to follow to prevent personal injury and environmental damage.

15. Declaration of Conformity

EC DECLARATION OF CONFORMITY ACCORDING DIRECTIVE 2006/42/EC ANNEX 11

INPRO R&D, S.L.
Pol. Ind. el Malvar
C/ Invierno Naves 4,6
28500 Arganda del Rey (Madrid)

Declare under our sole responsibility that the machine PUMPSET for oil,

Is manufactured in conformity with the following directives:

- Directive **2006/42/EC** of the European Parliament and of the Council of 17 May 2006 on machinery.
- Directive **2014/35/EU** of the European Parliament and of the Council of 26 February 2014 on the harmonization of the laws of the Member States relating to the making available on the market of electrical equipment designed for use within certain voltage limits Text with EEA relevance.
- Directive **2014/30/EU** of the European Parliament and of the Council of 26 February 2014 on the harmonization of the laws of the Member States relating to electromagnetic compatibility.

Manufacturer has no liability for:

- Not following of the instructions referred in the manuals delivered by INPRO R&D, S.L.
- Modifications to machine design not authorized by INPRO R&D, S.L.
- Damages caused during maintenance or repair performed by not authorized people by INPRO R&D, S.L.

For its construction EN 12.514-1, EN-ISO-9001 rules have been observed.



Oscar Servín Valderrama
Arganda del Rey, 2025

16. Inpro Guarantee

**2 YEARS AGAINST MANUFACTURING DEFECTS, INCLUDING MATERIALS, AND
LABOUR AT OUR MADRID WORKSHOPS**

INSTALLED AT: _____

NAME/COMPANY NAME: _____

ADDRESS:

TELEPHONE: _____

MODELO/TYPE: _____

SERIAL NUMBER (GĚRATE-NR): _____

INSTALLATION COMPANY: _____

NAME/COMPANY

NAME: _____

ADDRESS: _____

TELEPHONE: _____

PLEASE SEND US A COPY, DULY COMPLETED, WITHIN THIRTY DAYS, TO FAX NUMBER: (+34) 91 871 92 56

PRESSURE UNITS

GP 70 -1500



C/Invierno, 4-6
Pol. Ind. "El Malvar"
28500 Arganda del Rey
Madrid

Tel.: (+34) 91 871 92 94

Fax: (+34) 91 871 92 56

info@inprord.com

www.inprord.com

**PLEASE KEEP THIS BOOK
NEAR TO YOUR GP PRESSURE UNIT**

