

GPS-10 & GPS 10 MAXI



INSTALLATION MANUAL



1. GPS 10 Technical Specifications	4
2. GPS 10 Installation	5
3. Troubleshooting and maintenance	6
4. GPS 10 exploded view.....	7
5. Component and spare parts codes	7
6. Accessories – Leak detection system	8
7. GPS 10 Wiring diagram	9
8. Installation examples	10
9. Display quick reference list.....	11

1. GPS 10 Technical Specification

PUMP TYPE	Suction Solenoid Pump	
LIFTING HEIGHT (MAX.)	8 m vertical (8 mm I.D. tube)	
MÁX. HORIZONTAL DISTANCE	100 m horizontal (8 mm I.D. tube)	
OUTLET FLOW RATING (8 mm I.D. tube)	8 L/hr at: 8 m vertical & 25 m horizontal 15 l/hr at: 5 m vertical & 25 m horizontal	
INLET CONNECTION	3/8 " F BSP	
OUTLET CONNECTION	3/8 " F BSP	
OVERFLOW OUTLET CONNECTION	½ " F BSP	
POWER SUPPLY	AC 230V, 50Hz	
POWER CONSUMPTION	50 W	
	GPS 10	GPS 10 MAXI
RESERVOIR TOTAL CAPACITY	3,5 Litre.	12 Litre
DIMENSIONS: Width: Depth: Height:	(240 mm) (130 mm) (335 mm)	(350 mm) (225 mm) (345 mm)
WEIGHT	3 kg	4 kg
FUEL TYPE	Kerosene, Diesel Oil & HVO	

GPS 10

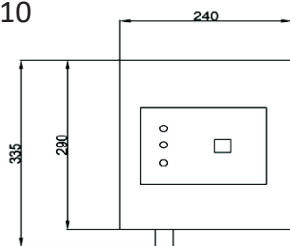

GPS 10 MAXI

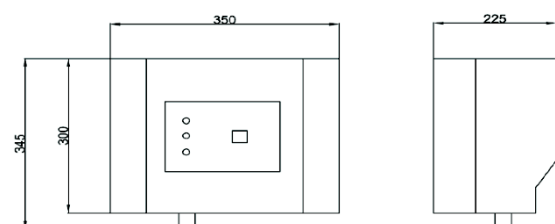

Installation must be in accordance with BS 5410 or any local building regulations.

1

Connect the suction line from the main tank to the 'inlet', and the "outlet" supply pipe ('gravity fed') to the appliance.

Connect the overflow facility (*). If your pipe is in PVC or copper you are required to use a 10mm pipe insert at any junction that has a compression fitting.

❶ The oil lifter requires a dedicated suction line from the oil tank.

2

Connect the equipment to the mains supply either through a plug (not included) or fused electric spur (see wiring diagram page 9). The mains supply cable has to pass through the access hole to the back part of the mounting plate.

Once powered up, low level led & green power light will come on.

To start the GPS automatic operation, press and keep pressed the start button, which will start the pump, filling the GPS 10 reservoir, until the low-level lamp turns off. The pump may be noisy initially until the fuel starts coming through to the pump.

3

Once the low level is reached, you can release the start button, because the GPS works in automatic mode.

Auto fill mode – Please read before installing the unit.

- Switch on 240v power to the unit
- Press start button and hold in.
- The GPS will display a light sequence.
- The pump will then start running/sucking.
- Release the start button when the low level & power LED's alternately flash. The unit is now in automatic mode.
- Whilst in automatic mode the lower 2 LED's flash intermittently. (see details P10)

Once the low level is reached, you can release the start button, because the GPS works in automatic mode.

4

Once the oil has filled the GPS 10 reservoir to the programmed maximum level (80% approx), the working level switch will stop the pump.

The GPS is now ready for use and the appliance(s) can be used. The GPS 10 will manage the fuel supply automatically.

5

(*) **The overflow connection** is dual purpose:

- 1) It must be connected with a return pipe to the tank as a safety feature in the event that the float switch fails. A leak detector & oil tray are available as an alternative if it is not possible to take the overflow back to the tank. The manufacturer will refuse any liability for damages at any installation without at least one these two additional safety options fitted.
- 2) It can be connected to the oil tank to allow venting of the GPS reservoir if it is required to be sealed to prevent unwanted smells.

3. Troubleshooting and maintenance

When under automatic function the vibration noise level is high or not stable, this could indicate that you have air entering the pump: Check suction line vacuum tightness, tube size, and distances related to suction limits of your GPS 10.

If the oil does not come up to the GPS 10:

- Check suction pipe for blockage and/or vacuum tightness.
- Is your vertical lift height lower than 8 mt?
- Check if the filter is not clogged or dirty

If the problem persists:

- Check pump suction power (with a vacuum gauge or by placing your hand at the filter inlet and pressing the start button to see if you can feel suction.
- Check power supply voltage
- Prime the suction line at the GPS 10. Then switch on the pump to pull this oil through and the oil from the tank.
- Check if there is oil in the main tank. After 1 hour pumping (=without oil at main tank), the pump will automatically stop.

Maintenance:

- Clean regularly the filter bowl and strainer.

Suction curve:

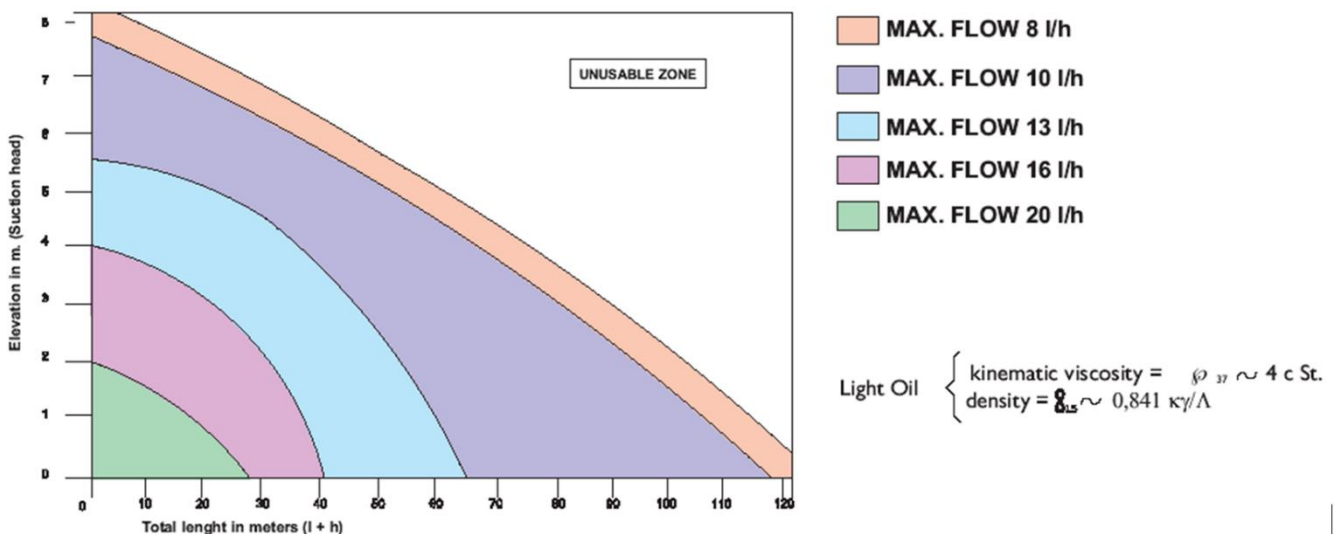

4. GPS 10 exploded view

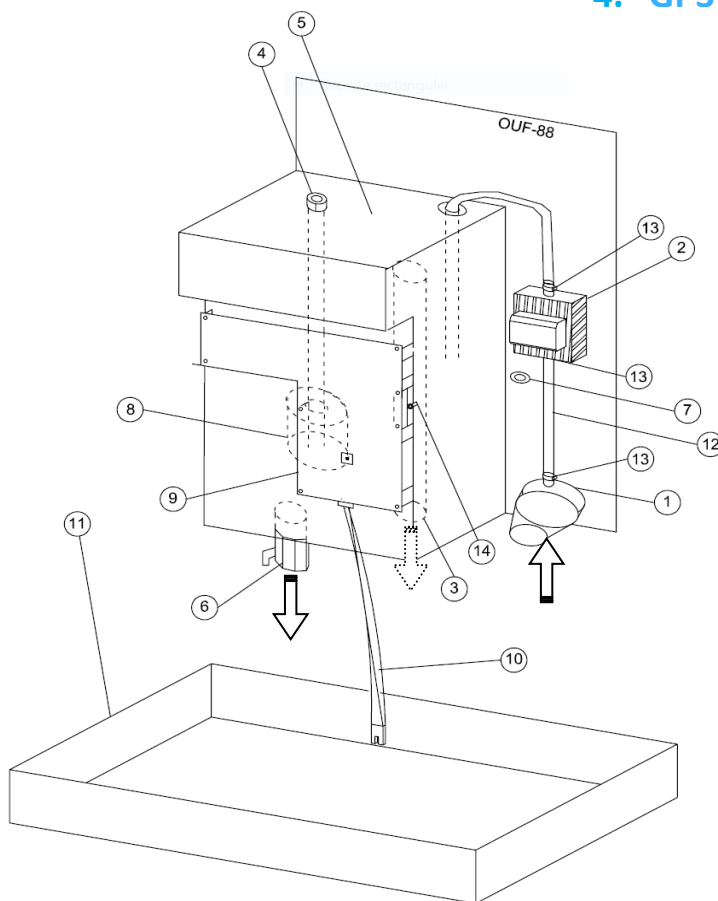

5. Component and spare parts codes

PART DESCRIPTION	Art. Nr.
1. FILTER 3/8 " BSP/ INLET CONNECTION	01110001004010
2. SOLENOID PUMP: (order with # 12 & 13 compression clips and pipe)	01000000004660
3. OVERFLOW 1/2 " BSP CONNECTION	-
4. LEVELPROBE GPS 10/MAXI - WORK/SEC.	23130000032010
5. OIL RESERVOIR (3 lts) or (MAXI 12 lts)	00000000000010
6. OUTLET CONNECTION 3/8 " BSP	01050000380167
7. POWER SUPPLY ACCESS HOLE	-
8. REPLACEMENT STAINLESS STEEL FLOAT Ø45*55*15mm	00230004154135
9.- GPS CONTROL CIRCUIT COMPLETE (Ver. 101)	23110000000810
10.- INFRARED PROBE FOR GPS 10, 50 cm long	23080000005010
11.- SPILL TRAY	23090000001000
12.- TRANSPARENT PIPE	01120000090805
13.- 1 SIDE COMPRESSED CLIPS 7.8/9.5	05080000000208
14.- EARH POST	-

Oil tray with leak detection system

An oil tray with an infrared leak detection system is included in your GPS 10.

How does the leak detection system function

Once installed, the function of your GPS remains unchanged, unless some liquid at the infrared probe activates the leak alarm, or any damage occurs to the probe.

Whilst a leak is activating the sensor, the sensor has a fault or the sensing probe is missing:

- The pump stops (when pumping or required to pump)
- The upper red “high level” LED light  comes on
This status will be maintained until the infrared probe is completely clean and dry again or replaced.
- Once the probe is clean or replaced, the system will fill up automatically again, unless the low level or high level alarm has been activated.

Installation of the leak detection system:

- 1.- Place and fix the spill tray horizontally under the equipment.
The distance between the bottom of the equipment and the tray must not exceed 25 cm.
- 2.- Place the infrared sensor in the blue clip in the oil tray, at the lowest possible position.
- 3.- Extract the yellow cap at overflow outlet
- 4.- Check that the upper LED  lights up when an obstacle is detected by the infrared probe, and that the pump turns off.

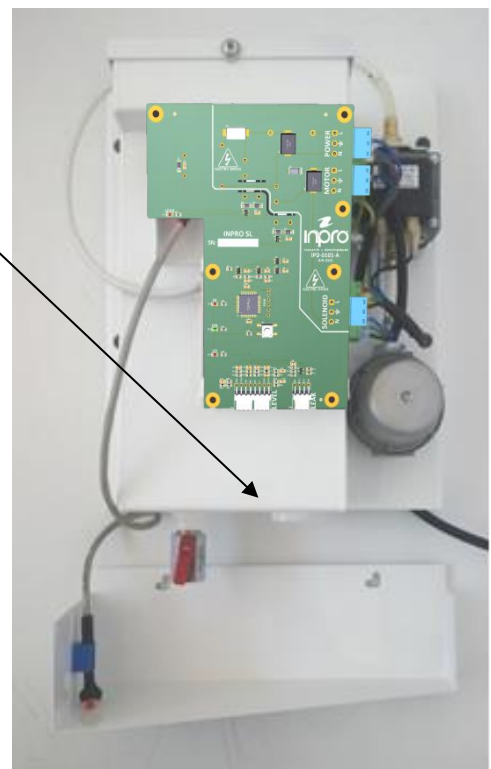

7. GPS 10 Wiring diagram

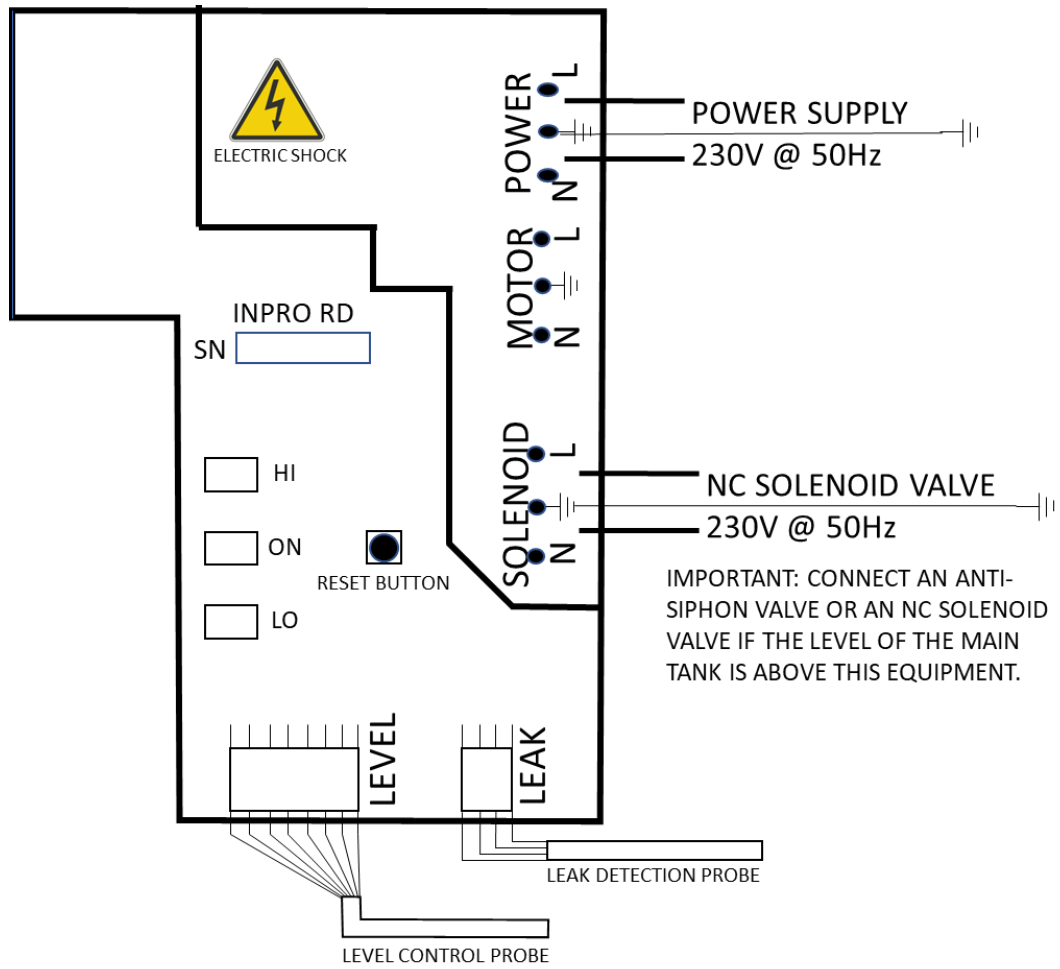

⚠ Warning: Make sure that earth is properly connected.



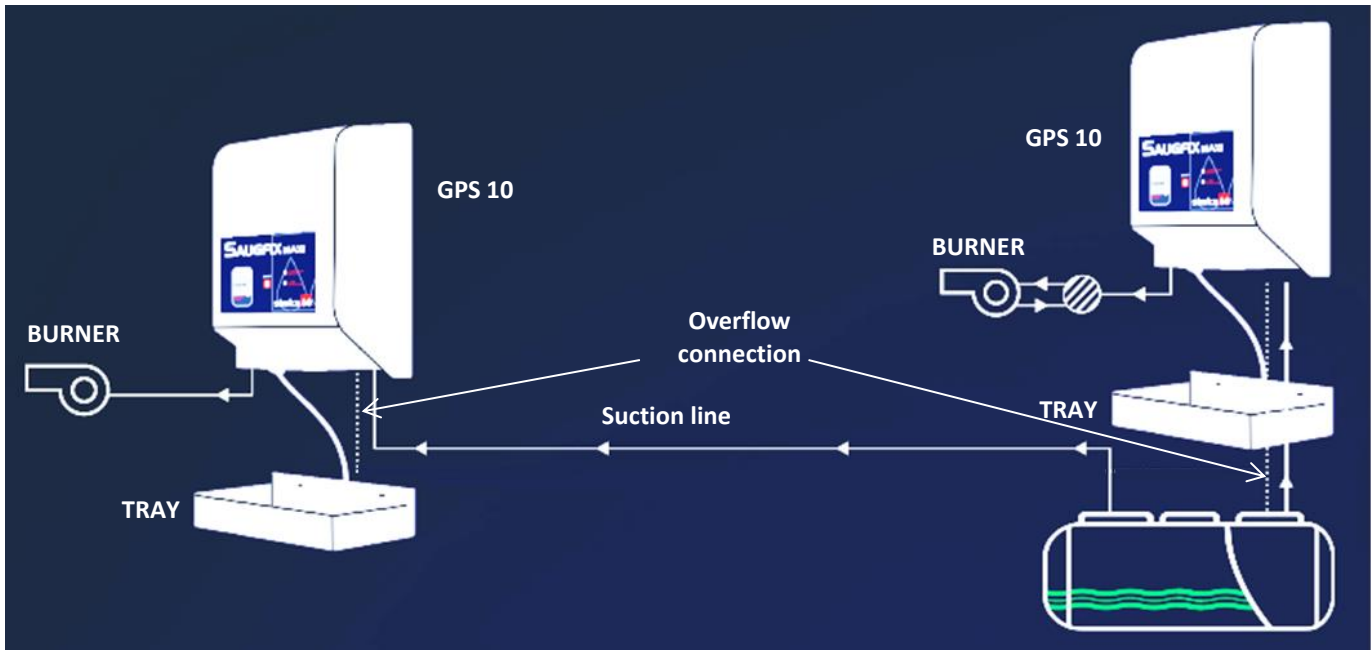

Important:

The Oil lifter requires a dedicated suction line from the oil storage tank, this will prevent any fuel starvation from any other appliance on the same suction line.

For outdoor use, a weather-proof protective cabinet must be used for the GPS 10.

Do not install below oil level at main tank, as siphoning may occur if no extra device is installed (anti siphon valve or NC solenoid valve).

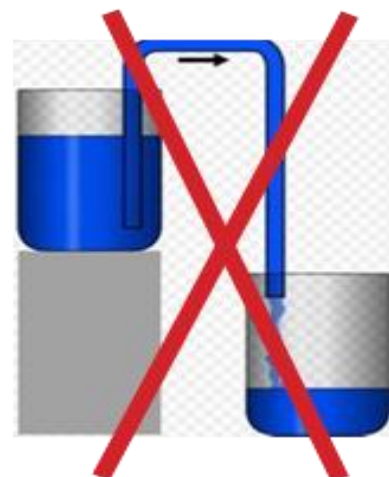

9. Display quick reference list

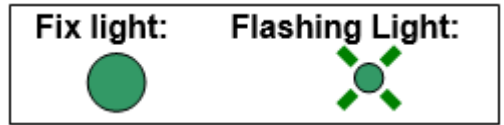

Normal Operation Status:

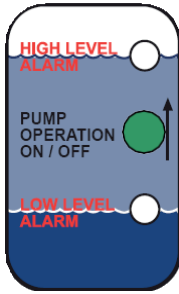

GPS 10 Oil Lifter is powered
Oil level in lifter reservoir has reached stop level. It keeps this state till low level is reached again, or start button

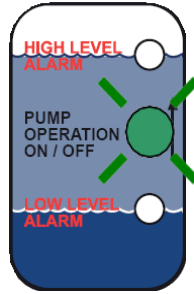

Pump filling
GPS reservoir

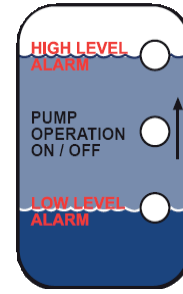

No Power Supply or Level probe
or PCB connector in short circuit

Alarm Status:

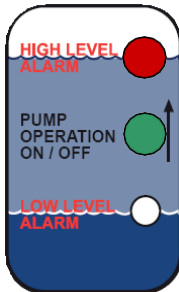

Very high level is reached

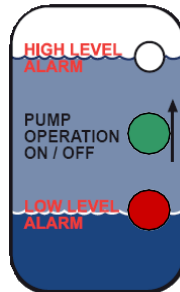

Very low level is reached

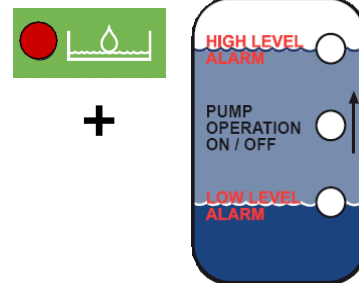

Leak detection alarm
(or fault at L.D. probe)

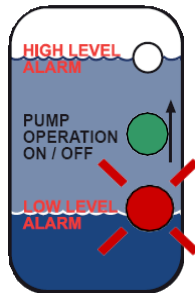

No oil Safety Stop:
Activated after 1 hour nonstop
running (=storage tank empty)

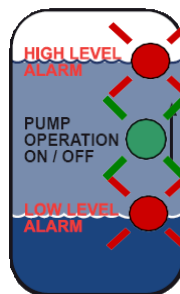

No level probe is detected

Other Status

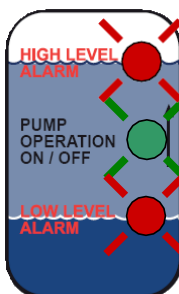

Reset Sequence
Following to an interruption to the power
automatically starts within 3 seconds

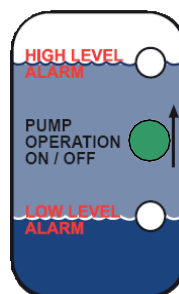

x 5 s

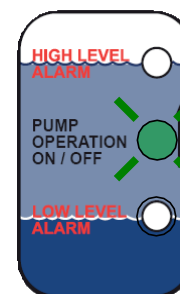
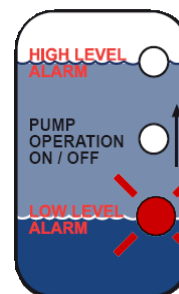

Automatic Start Mode facility

To enter, keep pressing start button during
5 green led blinks (5 sec approx)

GPS-10 & GPS 10 MAXI



research & development

C/Invierno 4-6
28500, Arganda del Rey, Madrid. SPAIN

www.inprogroup.net